

MhouseKit SL1-SL10

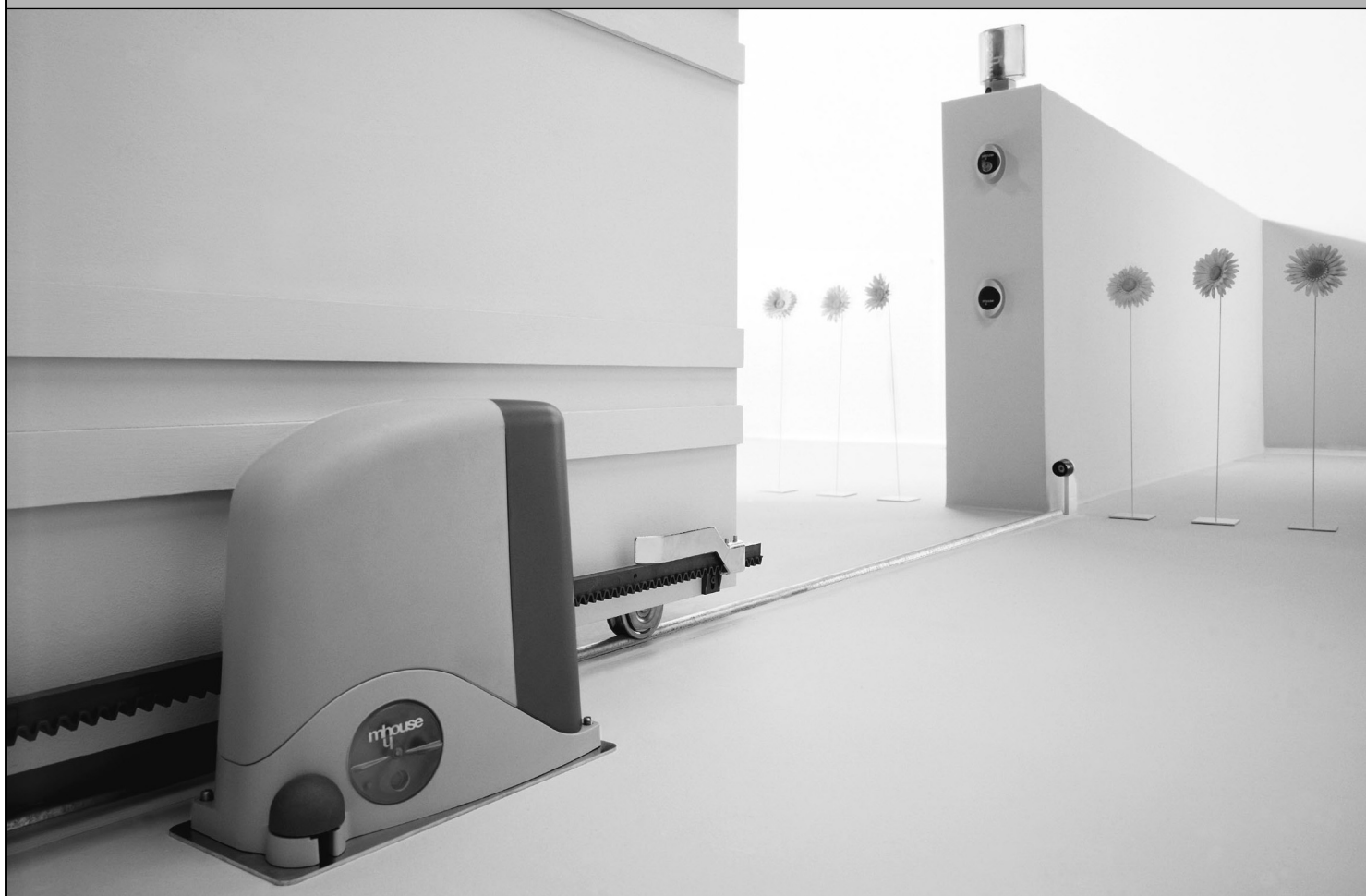

English

For the automation of sliding gates



Installation instructions and warnings

Information

This manual may be reproduced provided no part of it is omitted or modified. No part of this manual may be translated into other languages without the prior authorization and subsequent examination by MHOUSE.

MHOUSE disclaims all responsibility for damage resulting from improper use of its products. You are therefore invited to read this manual carefully.

MHOUSE, in order to improve its products, reserves the right to modify them at any time without prior notice. In any case, the manufacturer guarantees their functionality and fitness for the intended purposes.

For any information please contact:



MHOUSE S.r.l.

via Pezza Alta, 13, Z.I. 31046 Oderzo

Tel: 0422 202109

Fax: 0422 852582

email: info@mhouse.biz

http: www.mhouse.biz

WU2 is produced by NICE S.p.a. (TV) I, MHOUSE S.r.l. is an affiliate of the Nice S.p.a group.

Contents

1 Warnings	3	4 Maintenance	20
2 Product Description	4	4.1 Dismantling and Disposal	20
2.1 Applications	4	5 Additional information	21
2.2 Description of the automation	4	5.1 Advanced Adjustments	21
2.3 Description of devices	5	5.1.1 Adjusting the Parameters with the Radio Transmitter	21
2.3.1 Electromechanical gearmotor SL1K - SL10K	5	5.1.2 Checking the Adjustments with the Radio Transmitter	22
2.3.2 Release keys	6	5.2 Optional Accessories	22
2.3.3 PH1 photocells	6	5.3 Adding or Removing Devices	22
2.3.4 KS1 Key-Operated Selector Switch	6	5.3.1 ECSBus	22
2.3.5 FL1 flashing light with incorporated aerial	6	5.3.2 STOP Input	22
2.3.6 TX4 Radio Transmitters	6	5.3.3 Recognition of Other Devices	23
3 Installation	7	5.3.4 Addition of Optional Photocells	23
3.1 Preliminary checks	7	5.4 Memorization of Radio Transmitters	24
3.1.1 Operating Limits	8	5.4.1 Memorization Mode 1	24
3.1.2 Tools and Materials	8	5.4.2 Memorization Mode 2	24
3.1.3 List of cables	9	5.4.3 "Remote" Memorization	24
3.2 Preparing the Electrical System	9	5.4.4 Deleting a Radio Transmitter	25
3.2.1 Connection to the Electrical Mains	9	5.4.5 Deleting all the Radio Transmitters	25
3.3 Installation of the Various Devices	10	5.5 Troubleshooting	25
3.3.1 Mounting on gates without rack	10	5.6 Diagnostics and Signals	26
3.3.2 Mounting on gates with a rack	11	5.6.1 Photocells	26
3.3.3 Photocells	13	5.6.2 Flashing light	26
3.3.4 KS1 Key-Operated Selector Switch	13	5.6.3 Control Unit	27
3.3.5 FL1 Flashing Light	14	6 Technical Characteristics	28
3.3.6 Electrical connections to the SL1K - SL10K control unit	15	7 Annexes	30
3.4 Power Supply Connection	17	7.1 Annexe 1: CE Declarations of conformity of the SL1 and SL10 components	31
3.5 Initial checks	17	7.2 Annexe 2: CE Declaration of Conformity of Power Operated Gate	33
3.5.1 Recognition of Connected Devices	17	7.3 Annexe 3: Operating Guide	35
3.5.2 Checking gate movements	18	7.3.1 Safety regulations	35
3.5.3 Checking the Radio Transmitters	18	7.3.2 Gate Control	35
3.6 Regulations	18	7.3.3 Maintenance Operations to Be Performed by the User	36
3.6.1 Selecting gate speed	18	7.3.4 Replacing the Remote Control Battery	36
3.6.2 Selecting the Type of Operating Cycle	19		
3.7 Testing and Commissioning	19		
3.7.1 Testing	19		
3.7.2 Commissioning	19		

1 Warnings

• If this is the first time that you install a SL1 or SL10 gate automation system we recommend that you dedicate some of your time to reading this manual. You should read it before you start installing the system, so you don't have to rush to finish the work.

Keep all the components of the SL1 or SL10 system handy so that you can read, check and verify all the information contained in this manual. However, do not carry out the adjustment and memorization stages otherwise, during the actual installation of the products, you will have to deal with settings that differ from the original factory ones.

• When reading this manual, pay special attention to the sections marked by the following symbol:



these sections are particularly important for safety.

- Store this manual safely for future use.
- This manual, as well as the design and manufacture of the devices that make up SL1 or SL10, fully comply with the standards and regulations in force.
- Considering the hazards that may exist during the installation and operation of SL1 or SL10, it is necessary that the installation is carried out in strict compliance with current legislation, standards and regulations, particularly:
 - **This manual contains important information regarding personal safety; before you start installing the components, it is important that you read and understand all the information contained herein. Do not proceed with the installation if you have doubts of any sort; if necessary, refer to the MHOUSE customer service department for clarifications.**
 - **Before starting with the installation, make sure that each single SL1 and SL10 device is suitable for the intended automation purposes; pay special attention to the data provided in chapter 6 "Technical Characteristics". If even a single device is not suitable for the intended application, do not proceed with the installation.**
 - **Before starting with the installation, check whether additional devices or materials are needed to complete the automation with SL1 or SL10 based on the specific application requirements.**
 - **The SL1 and SL10 automation systems must not be used until the automation has been commissioned as described in paragraph 3.7.2 "Commissioning".**

• **The SL1 and SL10 automation systems cannot be considered as a suitable intrusion protection system. If you require efficient protection you need to integrate SL1 and SL10 with other devices.**

• **The packing materials of SL1 and SL10 must be disposed of in compliance with local regulations.**

• **Do not make modifications to any components unless provided for in this manual. This type of operations will only cause malfunctions. MHOUSE disclaims any liability for damage resulting from modified products.**

• **Components must never be immersed in water or other liquids. Also during installation, do not allow liquids to enter the gearmotor or other open devices**

• **In the event that liquid substances have penetrated inside the automation devices, immediately disconnect the power supply and contact the MHOUSE customer service department. Using SL1 and SL10 in these circumstances could create hazardous situations.**

• **Keep all SL1 and SL10 components away from heat sources and naked flames; these could damage the components and cause malfunctions, fire or hazardous situations.**

• **During long periods of inactivity, the optional battery (PR1) should be removed and stored in a dry location to prevent leakage of noxious substances.**

• **Connect the gearmotor only to a power supply line equipped with safety grounding system.**

• **All operations requiring the opening of the protection shell of any of the SL1 and SL10 devices must be performed with the control unit disconnected from the power supply (and from the PR1 buffer battery if present); if the disconnection device is not identifiable, post the following sign on it: "WARNING: MAINTENANCE WORK IN PROGRESS".**

• **In the event that any automatic switches or fuses are tripped, you must identify the failure and eliminate it before you reset them.**

• **If a failure occurs that cannot be solved using the information provided in this manual, refer to the MHOUSE customer service department.**

2 Product Description

2.1 Applications

The SL1 or SL10 are a set of components designed for the automation of a sliding gate in residential applications.

Any applications other than those described above or under different conditions from those specified in this manual are forbidden.

SL1 and SL10 are electrically operated. In the event of a power failure, the gearmotor can be released using a suitable key in order to move the gate manually. Alternatively, the PR1 buffer battery (optional accessory) can be used.

2.2 Description of the automation

To clarify a few terms and aspects of a gate automation system, here is an example of a typical SL1 and SL10 application.

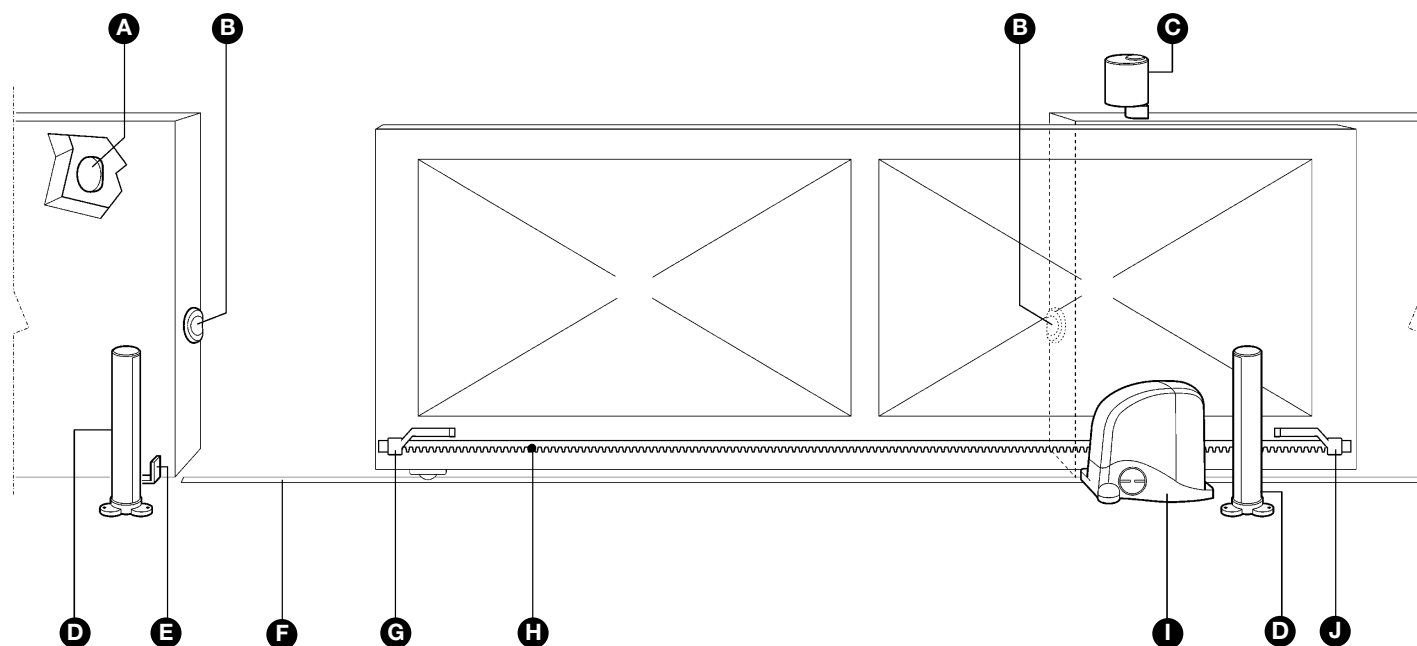

Figure 1

- | | |
|--|--|
| A) KS1 key-operated selector switch. | F) Ground guide (track) |
| B) Pair of PH1 photocells | G) Opening limit switch bracket. |
| C) FL1 flashing light with incorporated aerial. | H) CR100 rack (not included). |
| D) Pair of PT50 posts for photocells (not included). | I) SL1K or SL10K gearmotor including control unit. |
| E) Mechanical stop in closing cycle | J) Closing limit switch bracket. |

2.3 Description of devices

SL1 and SL10 consist of the devices shown in figure 2; make immediately sure that they correspond to the contents of the package and verify the integrity of the devices.

Note: to adapt SL1 and SL10 to local regulations, the contents of the package may vary; an exact list of the contents is shown on the outside of the package under the "Mhousekit SL1 contains" or "Mhousekit SL10 contains" heading.

- A)** 1 SL1K or SL10K electromechanical gearmotor with incorporated control unit and foundation plate.
- B)** 3 release keys.
- C)** 1 pair of PH1 photocells (consisting of a TX and an RX).
- D)** 2 TX4 radio transmitters.
- E)** FL1 flashing light with incorporated aerial.
- F)** 1 KS1 key-operated selector switch and two keys.
- G)** 2 limit switch brackets
- H)** Miscellaneous small parts: screws, screw anchors, etc. (see tables 1,2,3,4).

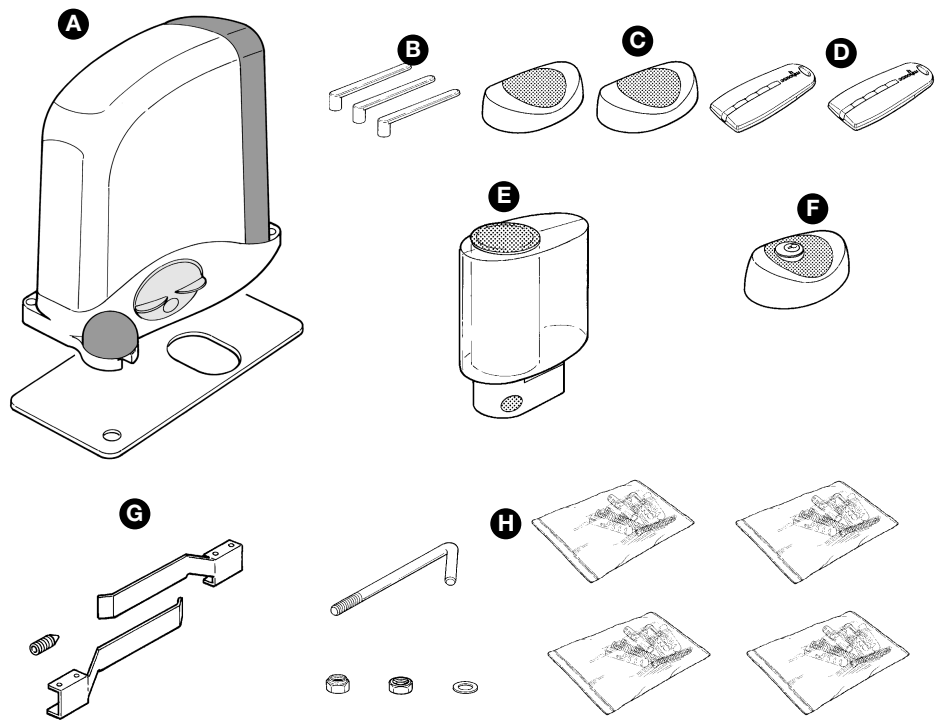

Figure 2

2.3.1 SL1K - SL10K electromechanical gearmotor

SL1 and SL10 are electromechanical gearmotors consisting of a helical teeth reduction gear and 24Vdc motor. It features a key-operated mechanical release mechanism that allows you to move the gate manually in the event of a power failure.

The gearmotor is fixed to the ground at the side of the gate with the relative foundation plate and operates the gate with a rack and pinion system.

The control unit actuates the gearmotors and provides for the control and supply of the different components; it features an electronic board with incorporated radio receiver.

SL1K and SL10K are equipped with an optional PR1 buffer battery compartment [C], which is necessary for operation in case of power failure.

The control unit can actuate the gearmotor with two speeds: "slow" and "fast".

The three P1, P2 and P3 buttons [B] and the corresponding LED's are used to program the control unit.

The yellow button allows the gate to be controlled locally during testing.

To facilitate the electrical connections there are separate terminals for each device [A], which are removable and colour-coded based on the function performed. Next to each input terminal there is a LED that signals its status.

The connection to the power supply is very easy: just insert the plug in a power outlet.

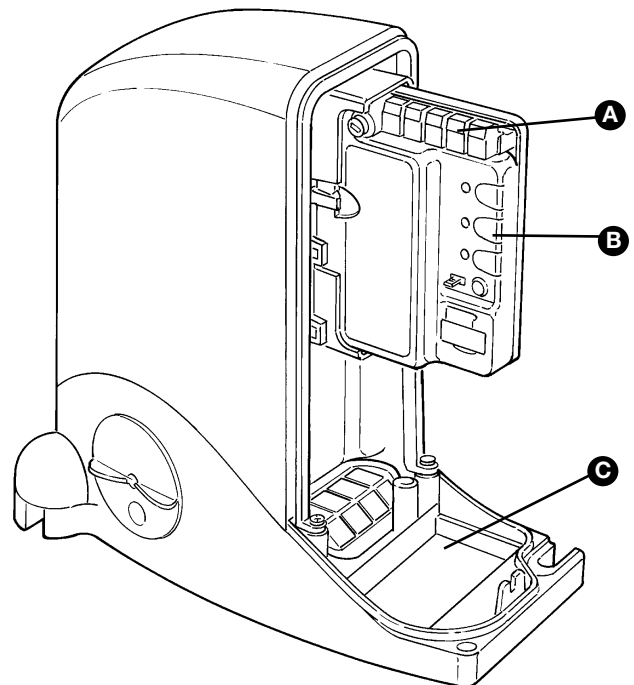

Figure 3

Table 1: List of small parts for a SL1K - SL10K

	Q.ty
Bent pins	2 pcs
M8 nuts	4 pcs
M8 self-tapping nuts	2 pcs
Ø10mm flat washers	2 pcs
6x14mm dowels	4 pcs
8x20mm dowels	4 pcs

2.3.2 Release keys

The three keys enable the gearmotor to be released in the event of a power failure.

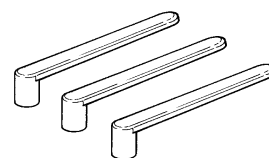

Figure 4

2.3.3 PH1 photocells

The pair of PH1 wall-mounted photocells, once they are connected to the control unit, enable the detection of obstacles found on the optical axis between the transmitter (TX) and the receiver (RX).

Table 3: List of small parts for PH1

	Q.ty
HI LO 4X9.5 screw	4 pcs.
3.5X25 self-tapping screw	4 pcs.
s 5 c nylon screw anchor	4 pcs.

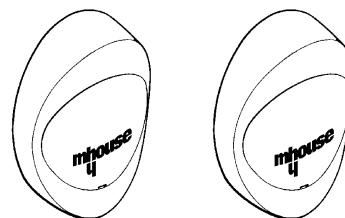

Figure 5

2.3.4 KS1 Key-Operated Selector Switch

The KS1 key-operated two-position selector switch enables gate control without using the radio transmitter. It is equipped with internal light for locating in the dark.

There are two commands, which depend on the direction of rotation of the key: "OPEN" and "STOP"; then the key, which is spring loaded, returns to the centre position.

Table 4: List of small parts for KS1

	Q.ty
HI LO 4X9.5 screw	4 pcs.
3.5X25 self-tapping screw	4 pcs.
s 5 c nylon screw anchor	4 pcs.

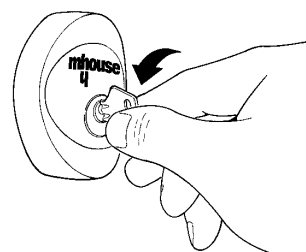

Figure 6

2.3.5 FL1 flashing light with incorporated aerial

The flashing light is controlled by the control unit and signals danger when the gate is moving. Inside the flashing light there is also the aerial for the radio receiver.

Table 5: List of small parts for FL1

	Q.ty
4.2X32 self-tapping screw	4 pcs.
s 6 c nylon screw anchor	4 pcs.

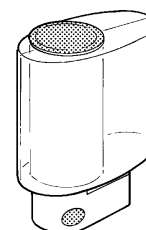

Figure 7

2.3.6 TX4 Radio Transmitters

The radio transmitters are used for the remote control of the gate opening and closing manoeuvres. They feature four buttons that can all be used for the 4 types of command to a single automation unit, or to control up to 4 different automation units.

The transmission of the command is confirmed by the LED [A]; an eyelet [B] allows them to be hung on a keyring.

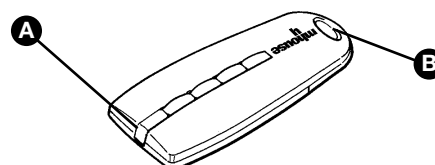

Figure 8

3 Installation

The installation must be carried out by qualified and skilled personnel in compliance with the directions provided in chapter 1 "Warnings".



3.1 Preliminary checks

SL1 and SL10 must not be used to power a gate that is not efficient and safe and cannot solve defects resulting from incorrect installation or poor maintenance of the gate.

Before proceeding with the installation you must:

- Make sure that the weight and dimensions of the gate fall within the specified operating limits. If they do not, SL1 and SL10 cannot be used.
- Make sure that the structure of the gate is suitable for automation and in compliance with regulations in force.
- Make sure that there are no points of greater friction in the opening or closing travel of the gate.
- Make sure there is no danger of the gate derailing.
- Make sure that the mechanical stops are sturdy enough and that there is no risk of the gate derailing out of the ground guide even when it hits the mechanical stop violently.
- Make sure that the gate is well balanced: it must not move by itself when it is placed in any position.
- Make sure that the area where the gearmotor is fixed is not subject to flooding. If necessary, mount the gearmotor raised from the ground.
- Make sure that the installation area is compatible with the size of the gearmotor and that it is safe and easy to release it.

- Make sure there is a suitable fixing surface at the points where the rack is fixed to the gate. For the CR100 rack, see figure 10.

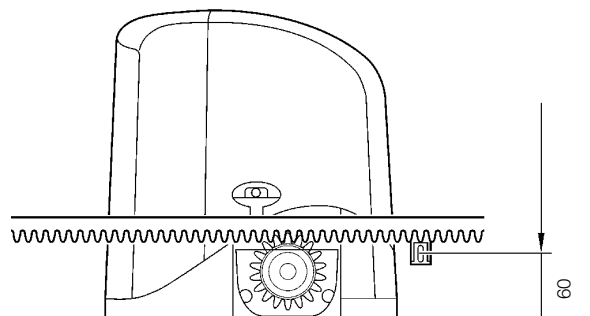

Figure 10

- Both with the gearmotor mounted to the left "LT" and to the right "RT", the distances indicated in figure 11 (gate without rack) or figure 12 (gate with rack) must be respected.

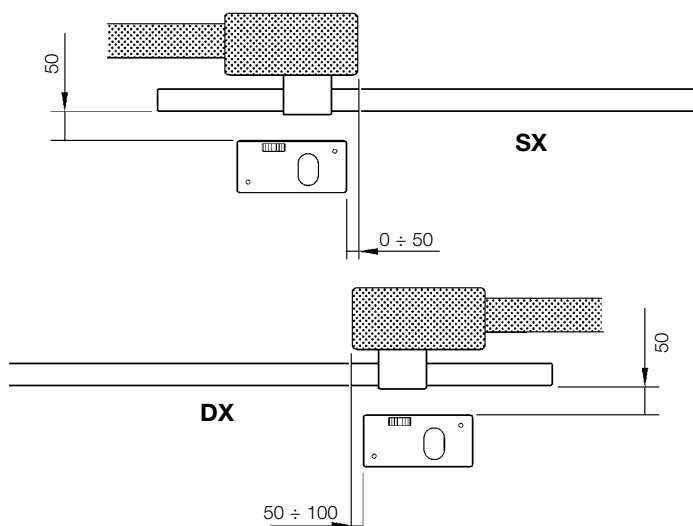

Figure 11

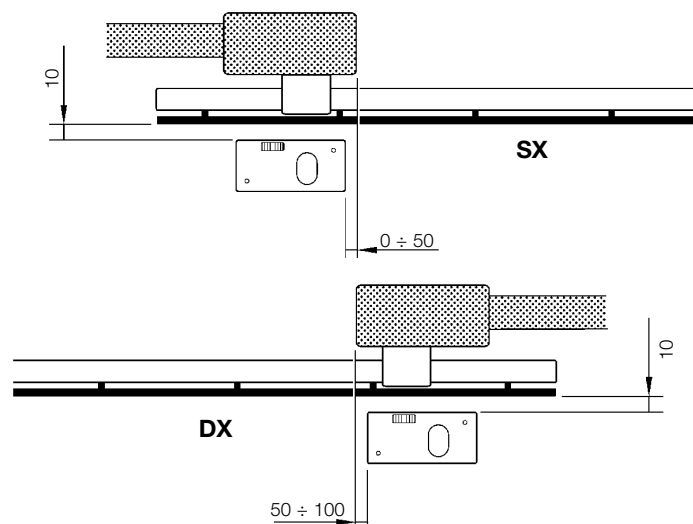

Figure 12

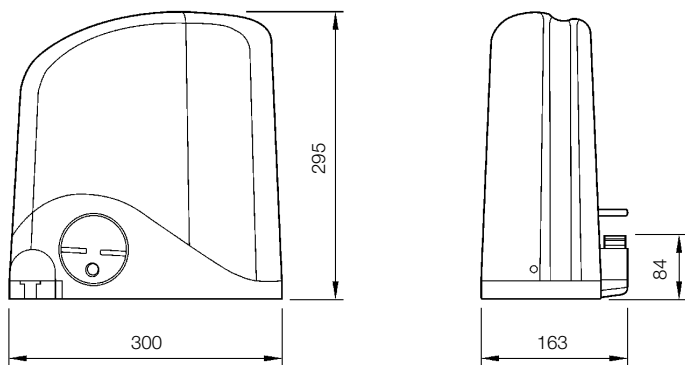

Figure 9

- Make sure that the mounting positions of the various devices are protected from impacts and that the mounting surfaces are sufficiently sturdy.
- Make sure that the mounting surfaces of the photocells are flat and that they enable the proper alignment between TX and RX.

• To mount the limit switch brackets, the rack (and therefore the gate) must project from the axis of the pinion by the distances indicated in figure 13 (LT opening) and figure 14 (RT opening).

If the rack is already mounted on the gate, make sure its position is compatible with the size limits indicated in figure 15 and check that the pitch of the rack is module 4 (approx. 12mm).



Figure 13

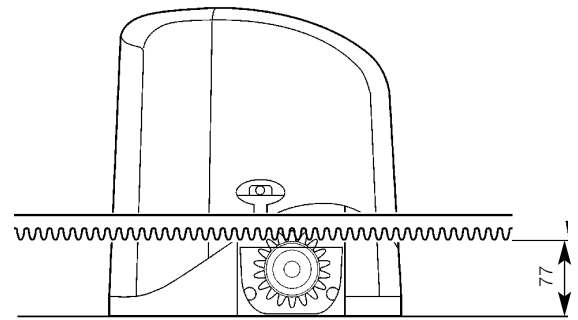

Figure 15

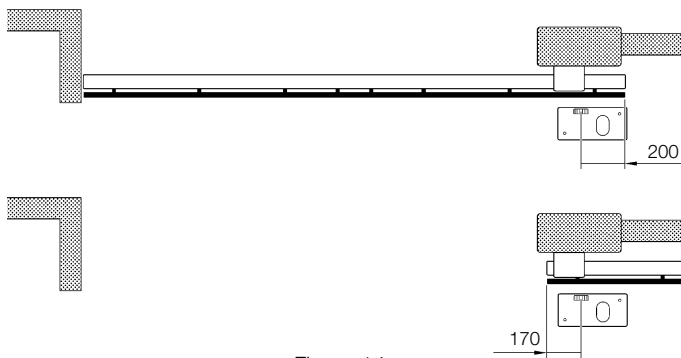

Figure 14

3.1.1 Operating Limits

Chapter 6 “Technical Characteristics” provides the fundamental data needed to determine whether all the SL1 or SL10 components are suitable for the intended application.

In general, SL1 is suitable for the automation of gates up to 5 m long, weighing up to 350 kg for residential applications; SL10 is suitable for the automation of gates up to 7 m in length and 500 Kg in weight for residential application.

The shape of the gate and the climatic conditions (e.g. presence of strong wind) may reduce these maximum limits. In this case it is necessary to measure the torque needed to move the gate under the worst conditions, and to compare it to the data provided in the technical characteristics chart for the SL1K and SL10K gearmotors.

3.1.2 Tools and Materials

Make sure you have all the tools and materials needed to install the system; make sure that they are in good condition and serviceable according to current safety standards. See examples in figure 16.

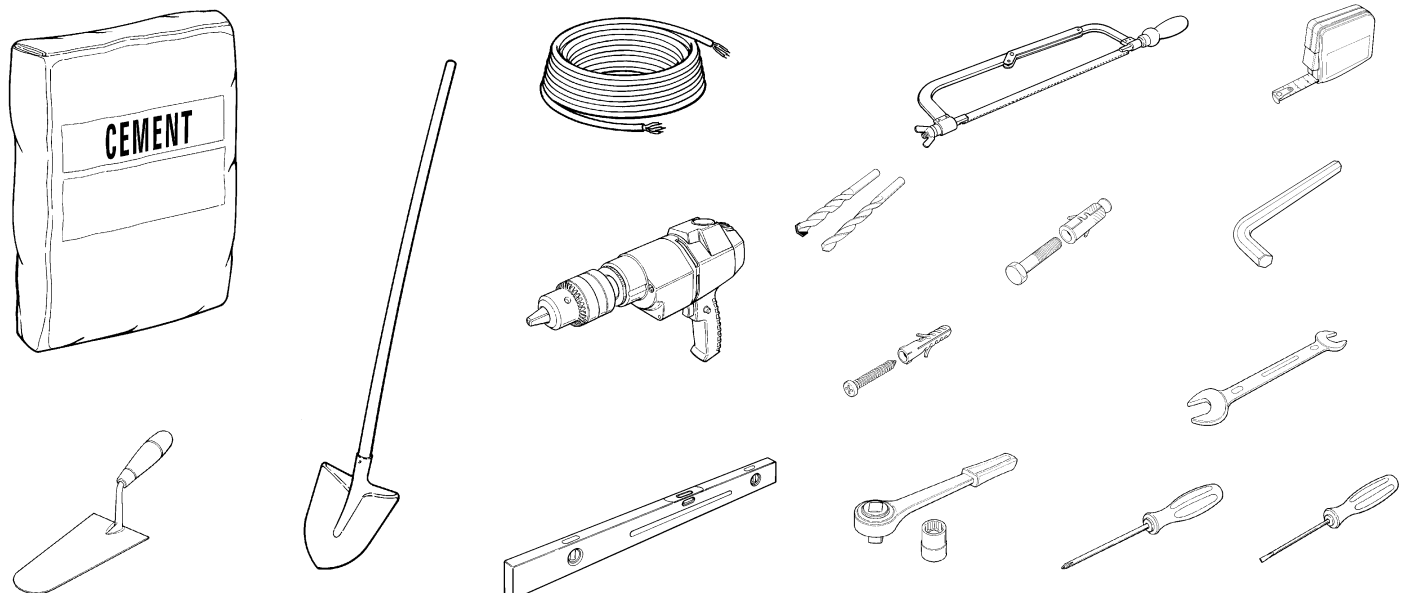

Figure 16

3.1.3 List of cables

The cables required for the installation of SL1 and SL10 may vary depending on the type and quantity of devices to be installed; figure 17 shows the cables needed for a typical installation; cables are not supplied with SL1 and SL10.

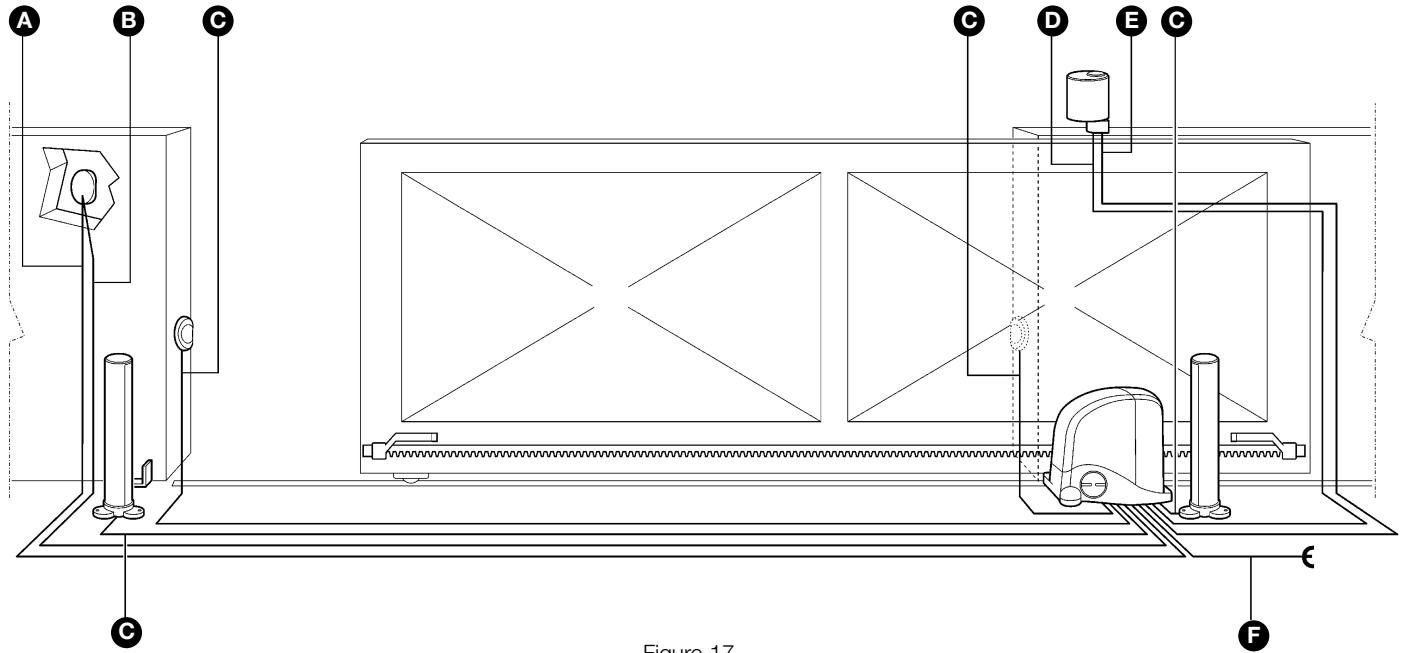

Figure 17

Table 5: List of cables

Connection	Cable type	Maximum length allowed
[A] STOP input	2x0,5mm ² cable	20m (note 2)
[B] OPEN input	2x0,5mm ² cable	20m (note 2)
[C] ECSBus input/output	2x0,5mm ² cable	20m (note 2)
[D] FLASH light output	2x0,5mm ² cable	20m
[E] Radio aerial	RG58 type shielded cable	20m(recommended less than 5m)
[F] Power supply line	3x1.5mm ² cable	30m (note 1)

WARNING: the cables used must be suitable for the type of installation; for example, an H03VV-F type cable is recommended for indoor applications, while H07RN-F is suitable for outdoor applications.

Note 1 A power supply cable longer than 30 m may be used provided it has a larger gauge, e.g. 3x2.5mm², and that a safety grounding system is provided near the automation unit.

Note 2 For the ESCbus, STOP and OPEN cables, there are no special contraindications to the use of a single cable that groups together multiple connections; for example, the STOP and OPEN inputs can be connected to the KS1 selector switch using a single 4x0,5mm² cable.

3.2 Preparing the Electrical System

With the exception of the power line, the rest of the system uses extra-low voltage (approx. 24V); the wiring can therefore be done by personnel that is not properly qualified, provided that all the instructions in this manual are carefully observed.

After selecting the position of the various devices (refer to figure 1) you can start preparing the conduits for the electrical cables connecting the devices to the control unit.

The conduits are designed to protect the electrical cables and prevent accidental breakage, which may be caused by the passage of vehicles, for instance.

3.2.1 Connection to the Electrical Mains

Although the connection of SL1 and SL10 to the mains power supply is beyond the scope of this manual, we wish to remind you that:

- **The power supply line must be laid and connected by a qualified professional electrician.**
- **The power supply line must be protected from short circuits and ground leakage; a bipolar disconnection device must also be present with contact separation of at least 3 mm, which allows**

the power supply to be disconnected during the installation and maintenance of the SL1 and SL10 (the plug with outlet are suitable for this purpose).



3.3 Installation of the Various Devices

The SL1K and SL10K gearmotors can be mounted in the two different situations:

A) Mounting on a gate without rack (paragraph 3.3.1); in this case the gearmotor must be installed first, followed by the CR100 rack.

B) Mounting on a gate with rack (paragraph 3.3.2); in this case the gearmotor must be adapted to the existing rack.

3.3.1 Mounting on gates without rack

1 Dig the foundations according to the "Preliminary checks" paragraph and in particular the distances indicated in figure 11 on page 10.

2 Lay the conduits for the power cables leaving them 30-50 cm longer.

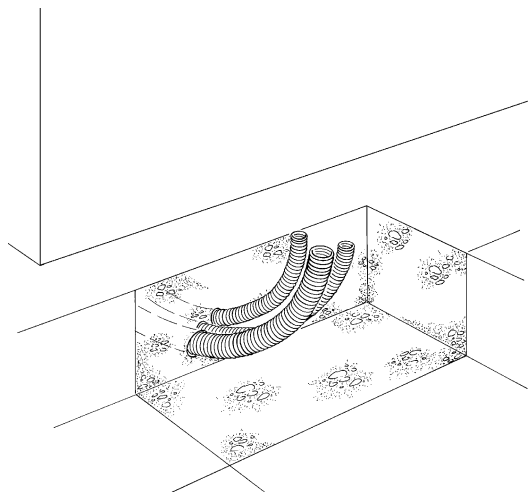

Figure 18

3 Fit the two bent pins [B] into the foundation plate and fix them above and below with two M8 nuts [A]; make sure the projecting part does not exceed the maximum height indicated in the figure.

4 Position the foundation plate making sure that the grooved side (indicating the position of the pinion) faces the gate observing the distances shown in figure 11.

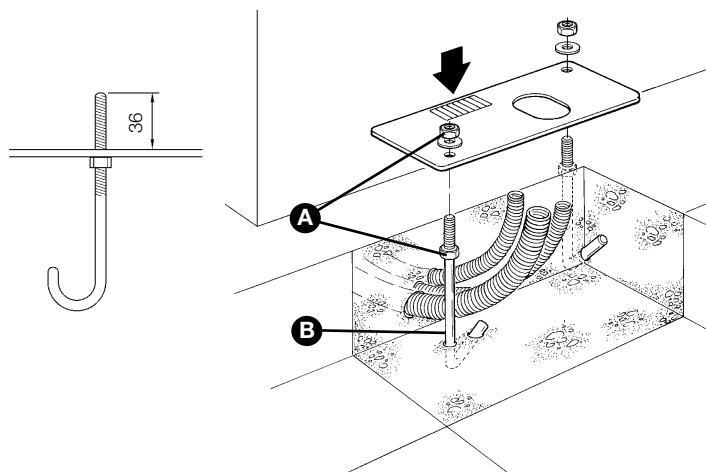

Figure 19

5 Fit the conduits through the hole in the foundation plate.

6 Pour the concrete.

7 Sink the plate into the concrete and make sure it is perfectly level.

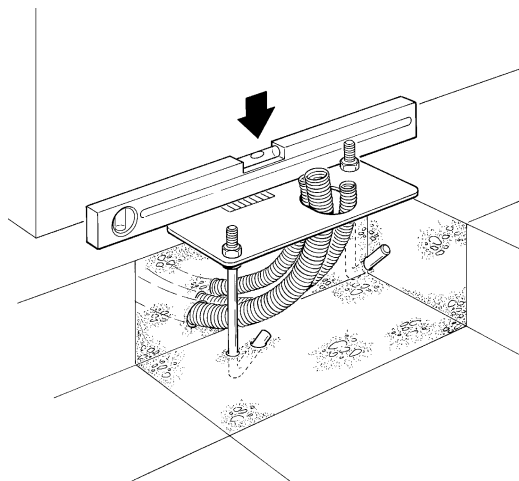

Figure 20

8 When the concrete is dry enough (after a few days), unscrew the two nuts over the plate as they will no longer be used.

9 Cut the cable conduits approximately 3-4cm above the plate.

10 Remove the nut cover on the gearmotor.

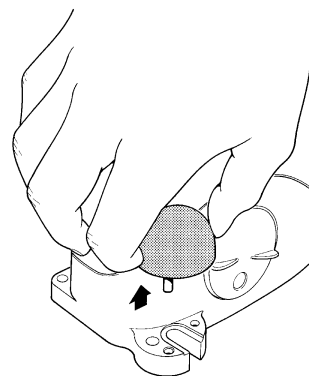

Figure 21

11 Place the gearmotor on the foundation plate, make sure it is perfectly parallel with the gate and fix it with two self-locking nuts [C] and washers [D]. Thoroughly tighten the two nuts.

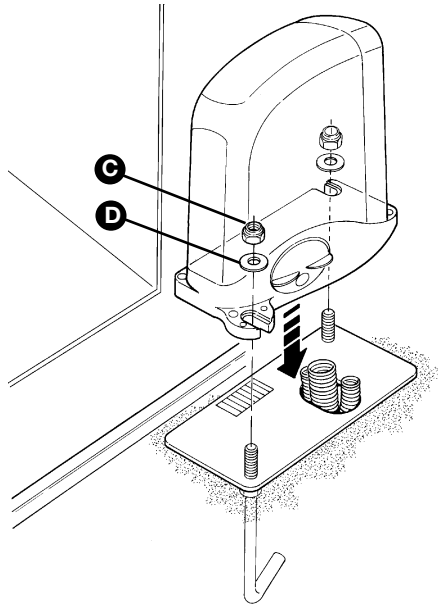

Figure 22

12 Release the gearmotor using the appropriate release keys (see the "Gearmotor release" paragraph on page 36).

13 Fully open the gate and place the first piece of the rack on the pinion so that it projects from the axis of the pinion by the distance indicated in figure 13 or figure 14, that is, the space required for the limit switch brackets.

14 To keep the rack level with the pinion, mark the hole for fixing when the slot matches the axis of the pinion. Repeat this operation for each fixing point.

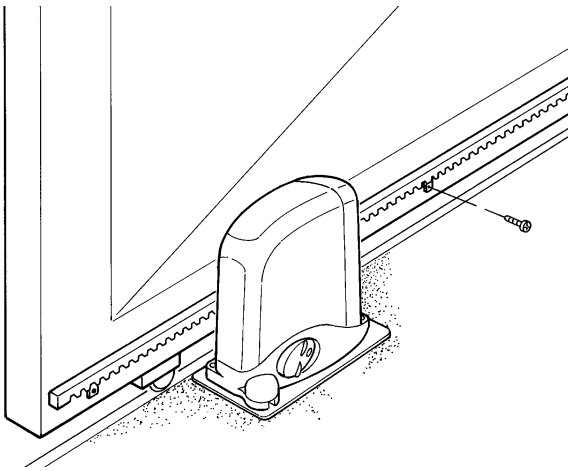

Figure 23

15 Leave a play of 1 mm between the rack and the pinion so that the gate does not weigh on the gearmotor.

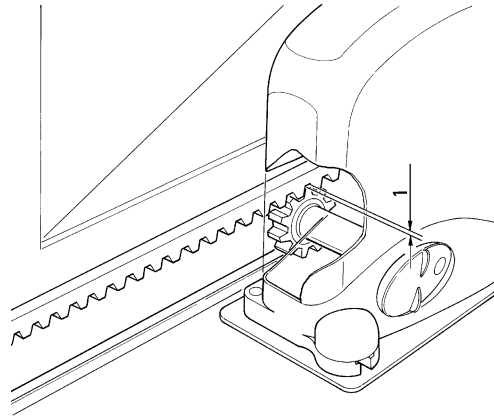

Figure 24

16 Mount the other pieces of the rack and align them one after the other with a play of 1 mm on the pinion.

17 After fixing the last piece, cut away the projecting part of the rack with a hacksaw if necessary.

18 Open and close the gate several times by hand and make sure that the rack is aligned with the pinion with a maximum tolerance of 5mm.

19 Fix the two limit switch brackets with the relative dowels [E] to the outer sides of the rack.

Consider that the gate will slide for about another 2-3 cm after the limit switch cuts in. The brackets should be positioned at a sufficient distance from the mechanical stops in order to prevent the gate from jamming.

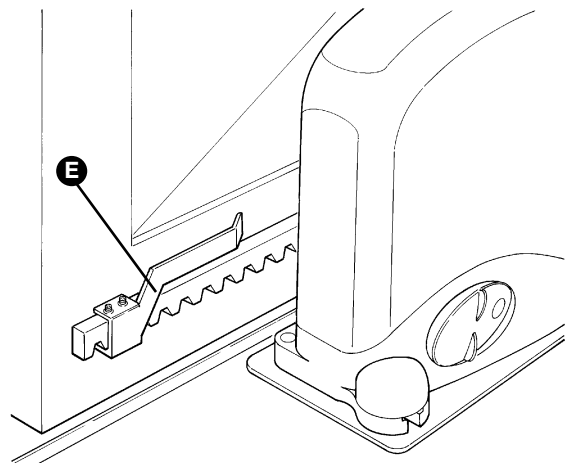

Figure 25

20 To electrically connect the various devices, see paragraph 3.3.6 "Electrical Connections" on page 15.

3.3.2 Mounting on gates with a rack

1 Dig the foundations according to the "Preliminary checks" paragraph and in particular the distances indicated in figure 11 on page 7. Make sure the foundation plate is 77 mm from the rack, see figure 15.

2 Lay the conduits for the power cables leaving them 30-50 cm longer.

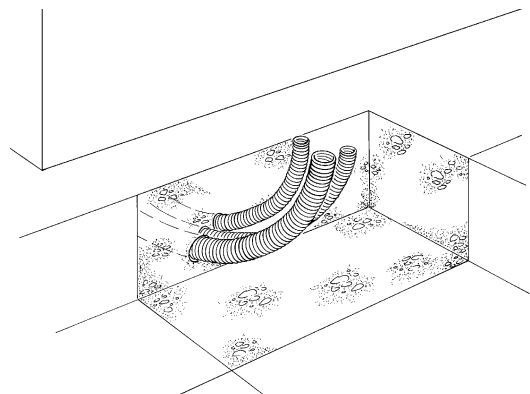

Figure 26

3 Fit the two bent pins [B] into the foundation plate and fix them above and below with two M8 nuts [A]; make sure the projecting part does not exceed the maximum height indicated in figure 27.

4 Position the foundation plate making sure that the grooved side (indicating the position of the pinion) faces the gate observing the distances shown in figure 11.

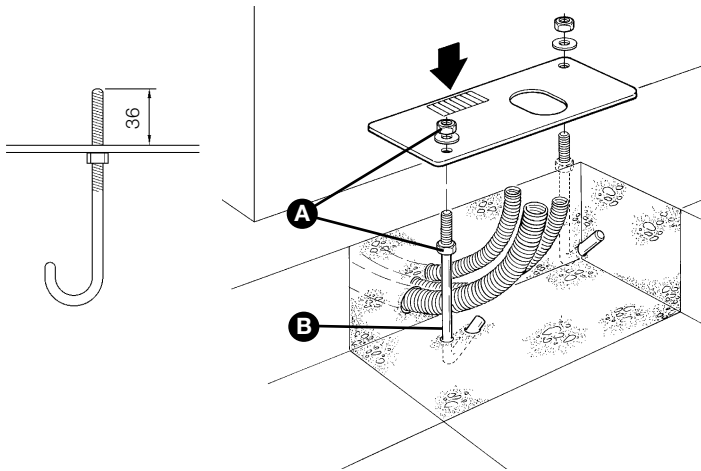

Figure 27

5 Fit the conduits through the hole in the foundation plate.

6 Pour the concrete.

7 Make sure the plate is sunk into the concrete and that it is perfectly level.

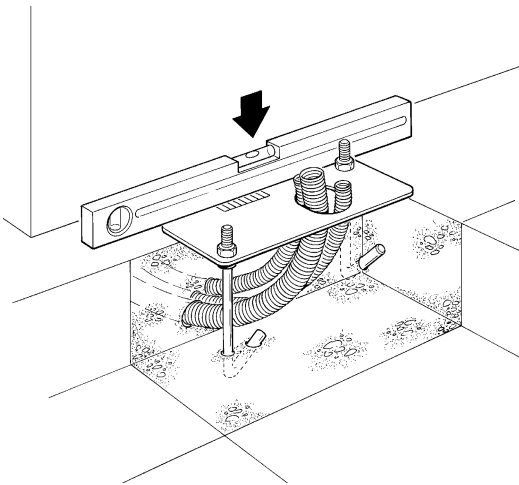

Figure 28

8 When the concrete is dry enough (after a few days), unscrew the two nuts over the plate which will no longer be used.

9 Cut the cable conduits approximately 3-4cm above the plate.

10 Remove the nut cover on the gearmotor.

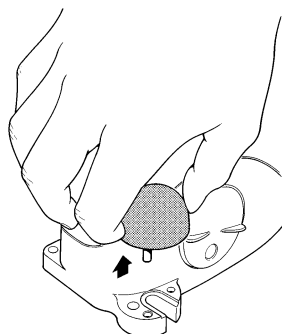

Figure 29

11 Fit the gearmotor to the foundation plate underneath the rack. This operation can be simplified by tilting the gearmotor so that the pinion can easily pass under the rack. Tighten the two self-locking nuts [C] a little after fitting the washers [D].

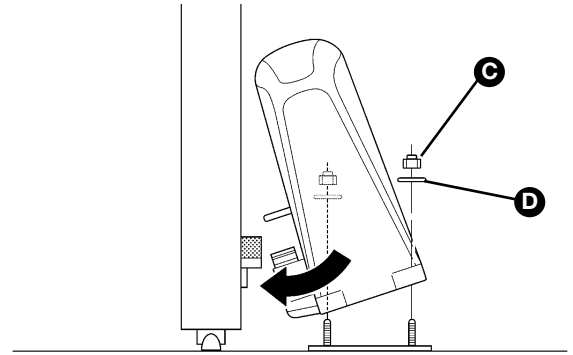

Figure 30

12 If necessary, adjust the height of the gearmotor (Max. 10mm) with the 4 dowels so that there is at least 1mm of play between the rack and the pinion so that the gate does not weigh on the gearmotor. It is better to fix the gearmotor without dowels as it will lie more firmly and securely on the plate.

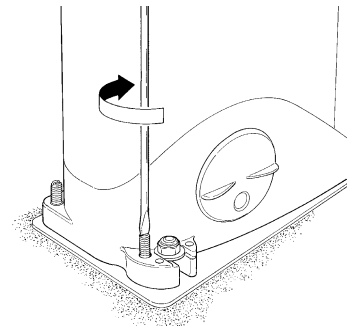

Figure 31

13 Make sure the gearmotor lies perfectly parallel with the gate. Then fix it to the foundation plate and fully tighten the two self-locking nuts [C].

14 Release the gearmotor using the appropriate release keys (see the "Gearmotor release" paragraph on page 36).

15 Open and close the gate several times by hand and make sure that the rack is aligned with the pinion with a maximum tolerance of 5mm.

16 Fix the two limit switch brackets with the relative dowels [E] to the outer sides of the rack.

Consider that the gate will slide for about another 30mm after the limit switch cuts in. Position the brackets so that the gate does not jam.

17 To electrically connect the various devices, see paragraph 3.3.6 "Electrical Connections" on page 15.

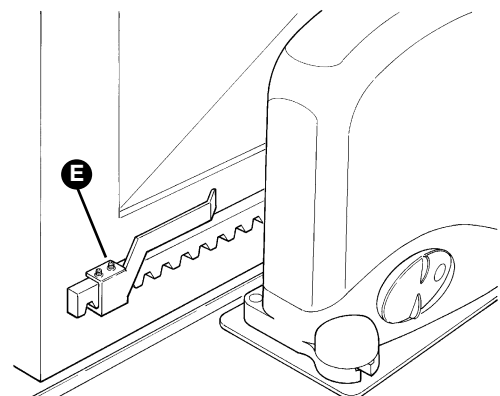

Figure 32

3.3.3 Photocells

1 Select the position of the two elements that make up the photocell (TX and RX) observing the following directions:

- Position them at a height of 40-60 cm from the ground, on both sides of the area to be protected, on the street side of the installation and as close as possible to the edge of the gate, no farther than 15 cm.
- Point transmitter TX towards receiver RX, with a maximum tolerance of 5°.
- In the selected locations there must be a conduit for threading the cables.

2 Remove the front glass [A] by prising it out with a slotted tip screwdriver applied to the bottom.

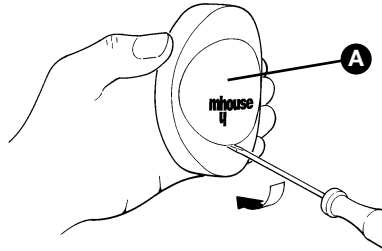

Figure 33

3 Press the lens in order to separate the two shells.

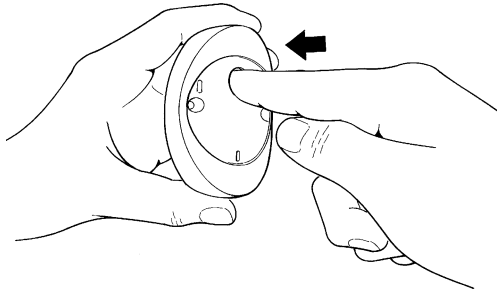

Figure 34

4 Breach two of the four holes [B] at the bottom with a screwdriver.

5 Position the photocell at the point where the conduit arrives; the hole at the bottom [D] should match the point where the cables come out of the wall; mark the drilling points using the bottom as reference.

6 Drill the holes in the wall using a hammer drill with a 5 mm bit and insert the 5 mm screw anchors.

7 Secure the bottom with the screws [C].

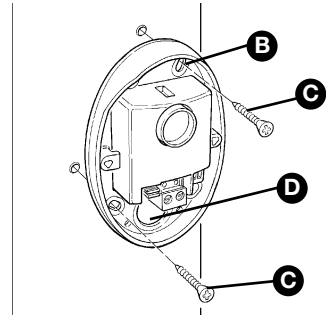

Figure 35

8 Connect the electric cable to the appropriate TX and RX terminals. From an electrical viewpoint, TX and RX must be connected in parallel as shown in figure 36. It is not necessary to observe any polarity. The terminals can be removed in order to facilitate the operations; make the connections and then reinsert them.

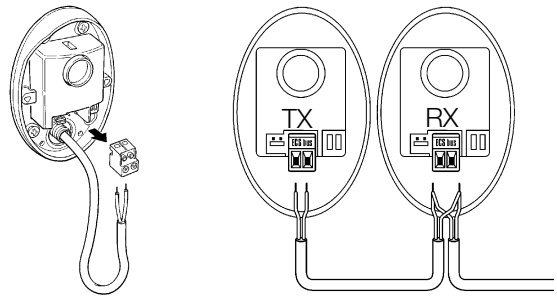

Figure 36

9 Secure the cover shell [E] using the two screws [F] and a Phillips screwdriver. Then insert the glass [G], pressing it gently to close it.

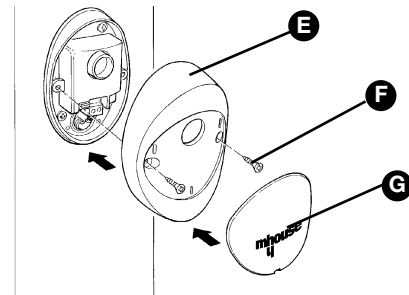

Figure 37

3.3.4 KS1 Key-Operated Selector Switch

1 Determine the position of the selector switch; it must be installed outdoors, alongside the gate and at a height of approx. 80 cm, so that it can be used by people of different height.

2 Remove the front glass [A] by prising it out with a slotted tip screwdriver applied to the bottom.

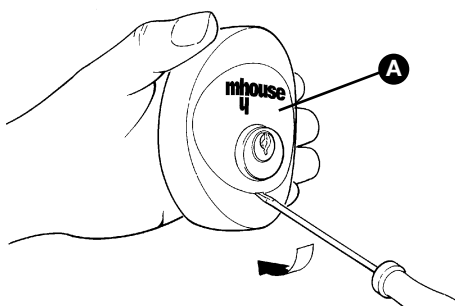

Figure 38

3 To separate the bottom from the shell you need to insert the key and keep it turned, then pull with a finger inserted in the hole for the passage of the cables.

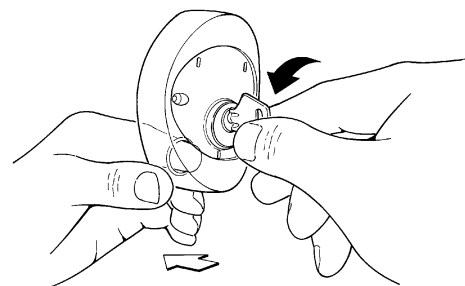

Figure 39

4 Breach the four holes at the bottom with a screwdriver; mark the drilling points using the bottom as reference; make sure that the hole in the bottom matches the outlet for the cables.

5 Drill the holes in the wall using a hammer drill with a 5 mm bit and insert the 5 mm screw anchors.

6 Secure the bottom using the four screws [B].

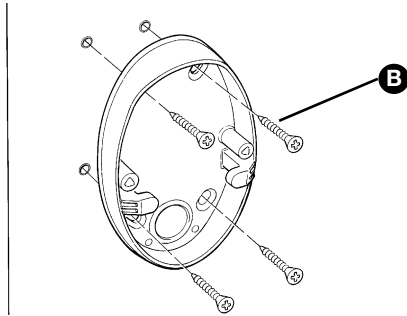

Figure 40

7 Connect the electric cables to the appropriate OPEN and STOP terminals, as shown in figure 41. It is not necessary to observe any polarity. The terminals can be removed in order to facilitate the operations; make the connections and then reinsert them.

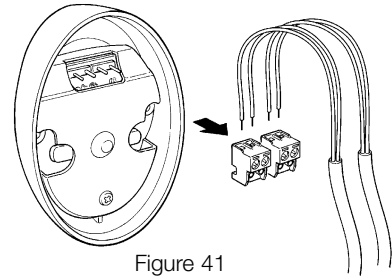

Figure 41

8 To insert the shell on the bottom you need to turn the key. After you have inserted it, turn the key back to the centre position.

9 Secure the body [C] using the two screws [D] and a Phillips screwdriver. Finally insert the glass [E], pressing it gently to close it.

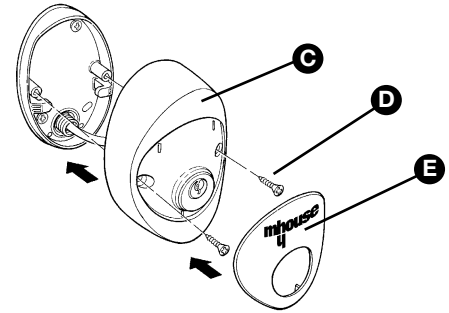

Figure 42

3.3.5 FL1 Flashing Light

1 Determine the position of the flashing light: it should be near the gate and easy to see; it can be secured to a horizontal as well as vertical surface.

2 Slide out the diffuser [A] from the bottom by pressing the two buttons [B].

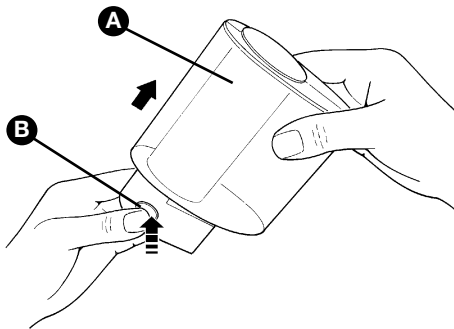

Figure 43

3 Separate the lamp holder with the aerial from the base.

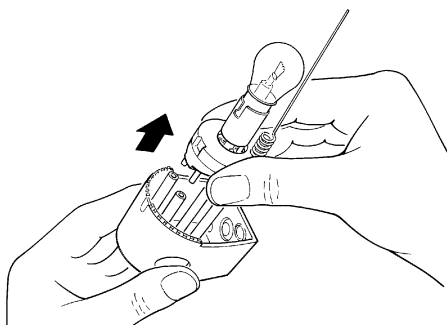

Figure 44

4 Breach the four holes for the screws and the hole for the passage of the cables in the bottom or side, depending on the installation position, using a screwdriver.

5 Mark the drilling points using the bottom as reference and make sure that the hole in the bottom matches the outlet for the cables.

6 Drill the holes in the wall using a hammer drill with a 6 mm bit and insert the 6 mm screw anchors.

7 Secure the bottom with the screws [C].

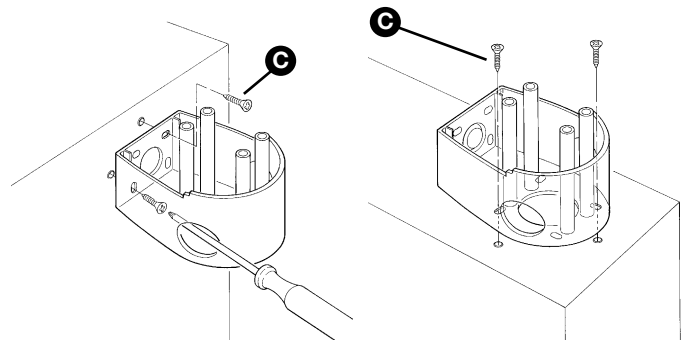

Figure 45

8 Connect the electrical cables to the appropriate FLASH and "aerial" terminals as shown in figure 46. You do not need to observe any polarity on the FLASH terminal; however, for the connection of the shielded cable to the aerial, connect the braid as shown in figure 47. The terminals can be removed in order to facilitate the operations; make the connections and then reinsert them.

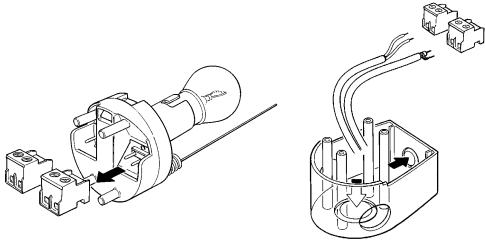

Figure 46



Figure 47

9 Fit the lamp holder on the base and press it down until it snaps into position.

10 Slide in the diffuser, pressing the buttons and fitting it on the bottom. Rotate it in the desired direction then press it down until the two buttons snap into their seat.

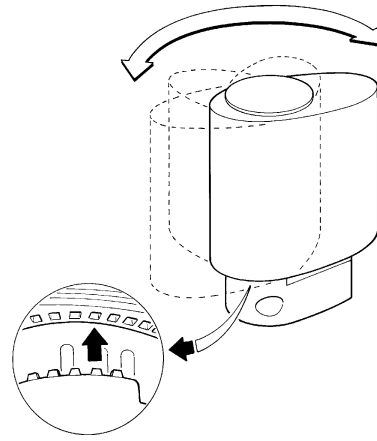

Figure 48

3.3.6 Electrical connection to the SL1K - SL10K control unit

1 Remove the side cover of the gearmotor by unscrewing the screw with a screwdriver and pulling up the cover.

3 Remove the rubber membrane closing the hole for the cables. Thread the cables required for connections to the various devices along the conduits. Keep the cables at least 40-50cm long.

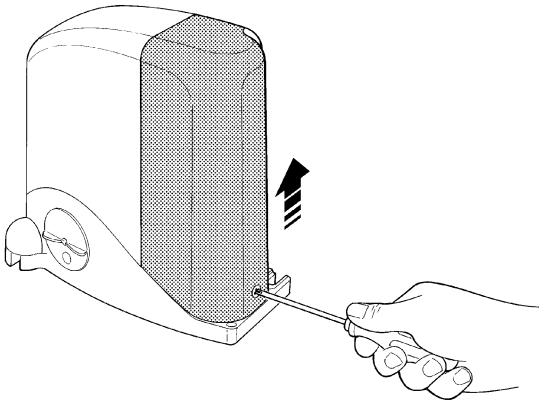

Figure 49

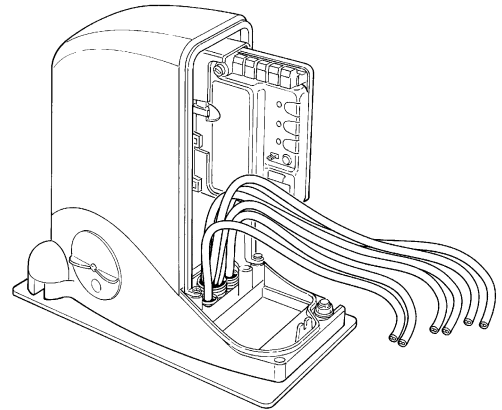

Figure 52

2 Depending on whether the gearmotor is on the right or the left, adjust the jumper selecting the direction of the "Open" manoeuvre as shown in figure 50 or figure 51.

4 Remove enough of the inner mesh from the rubber membrane to allow the cables to be threaded through. Lastly, push back the membrane.

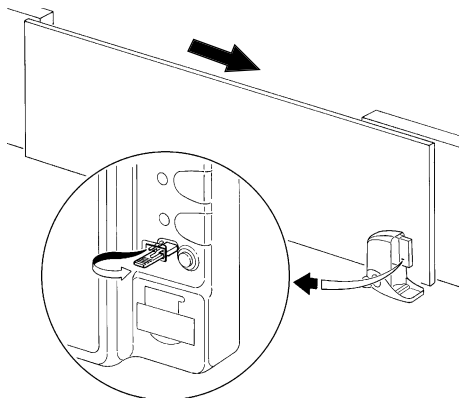

Figure 50

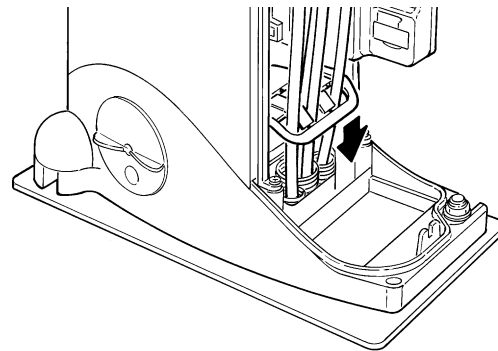

Figure 53

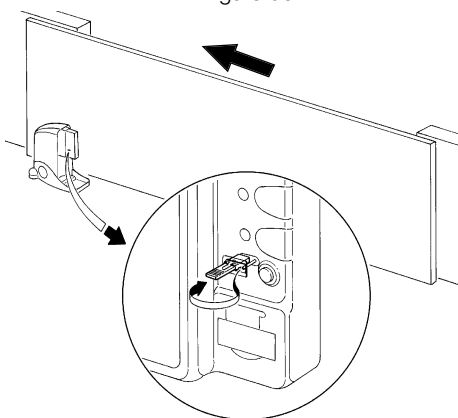

Figure 51

5 Refer to figure 54 for the electrical extra low voltage connection of the various devices to the control unit terminals.

- The terminals have the same colour coding as the corresponding devices; for example, the grey terminal (OPEN) of the KS1 selector must be connected to the grey terminal (OPEN) of the control unit.

- For most connections you do not need to observe any polarity; only for the shielded cable of the aerial it is necessary to connect the central core and the shield as shown in detail [A].

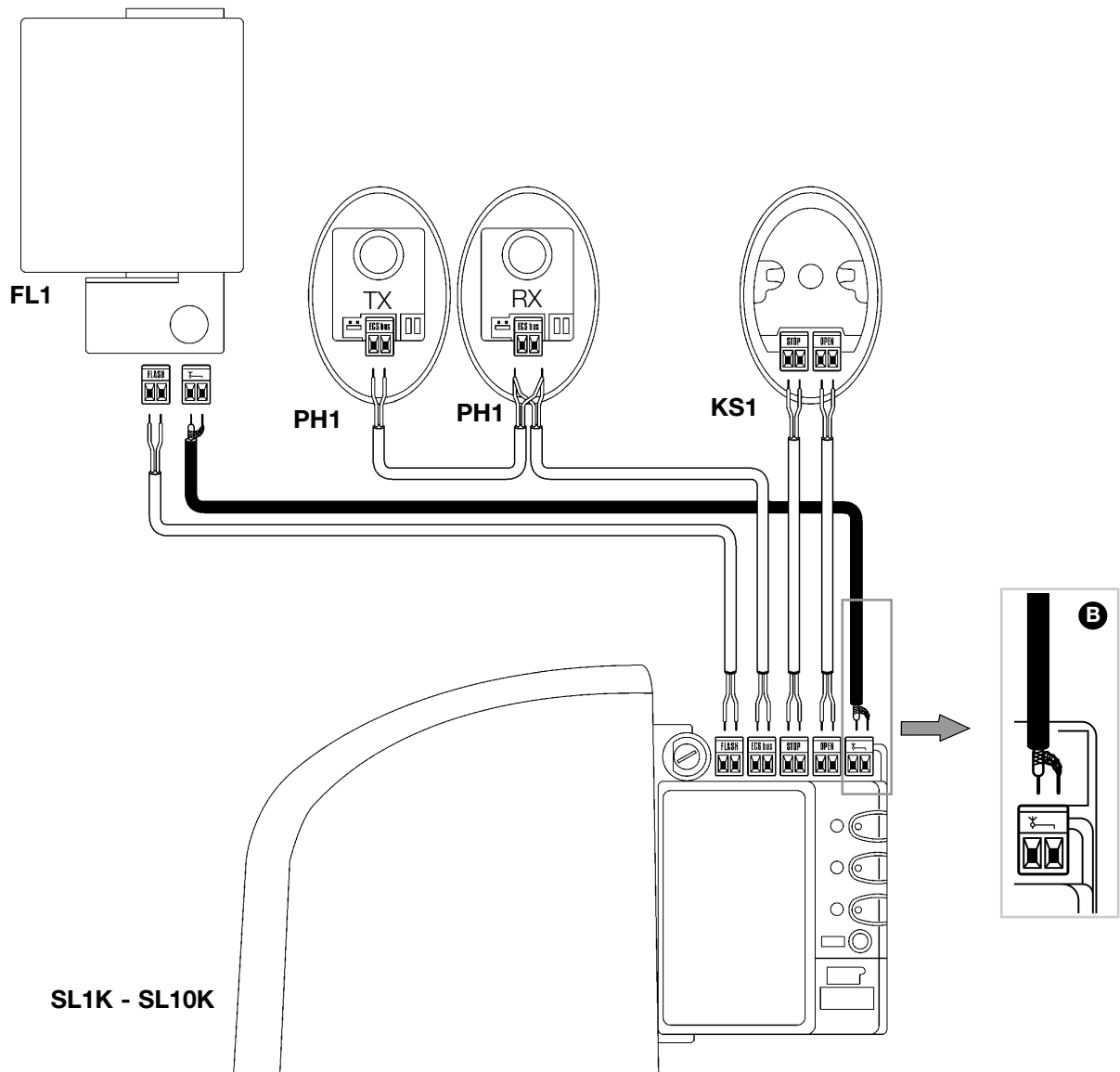

Figure 54

The terminals can be removed in order to facilitate the operations [A] as shown in figure 55; make the connections and then reinsert them.

6 Close the side cover of the gear motor by sliding it on from above and tighten the screw with a screwdriver.

When you have completed the connections, use clamps to secure the cables to the appropriate fasteners [B].

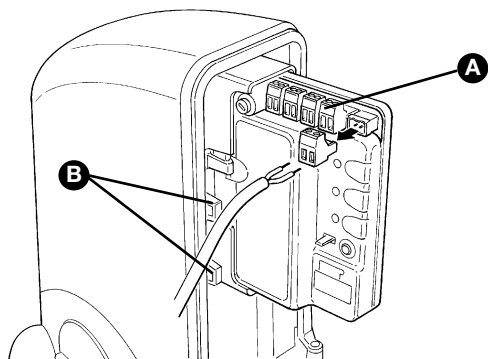

Figure 55

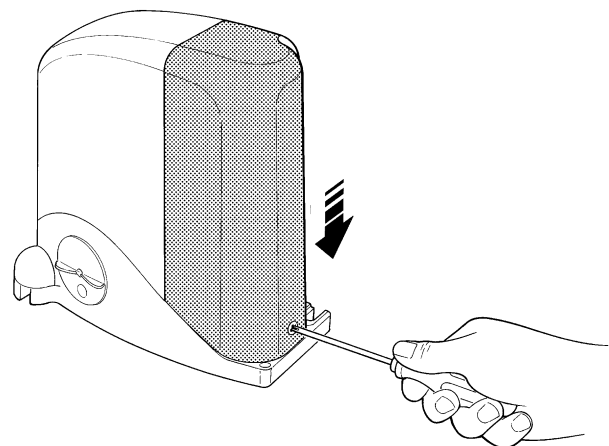

Figure 56

3.4 Power Supply Connection

To carry out tests, insert the plug of the gearmotor in a power supply socket, using an extension lead if necessary.

The gearmotor must be permanently connected to the mains power supply for the testing and commissioning operations.

This operation must be performed as follows by a qualified electrician:

- 1 Make sure that the plug of the gearmotor is not plugged-in to the power socket.
- 2 Disconnect the power cable from the gearmotor power supply terminal
- 3 Slacken the collar beneath the terminal and remove the cable.
- 4 Insert the final power supply cable of the gearmotor through the collar.
- 5 Connect the cable to the terminal of the gearmotor.
- 6 Tighten the collar.

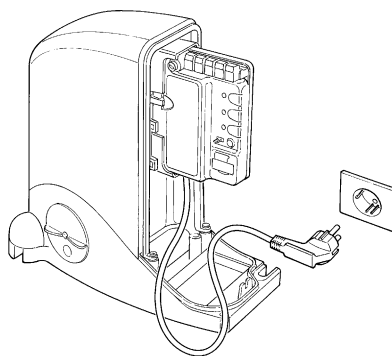

Figure 57

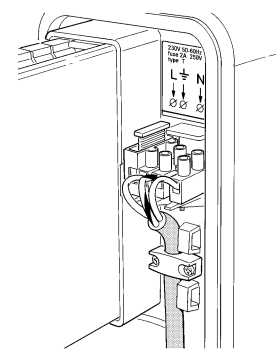

Figure 58

3.5 Initial checks

As soon as the control unit is energized, you should check the following:

- 1 Make sure that the "ECSBus" LED [A] flashes regularly, with about one flash per second.

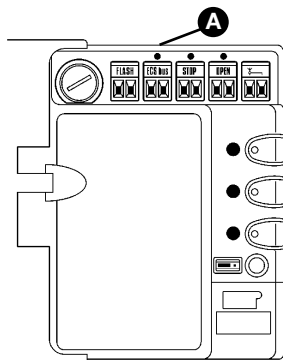

Figure 59

- 2 Make sure that the SAFE LED [B] on the photocells flashes (both on TX and RX); the type of flashing is not important as it depends on other factors; what is important is that the LED should not be steadily on or steadily off.

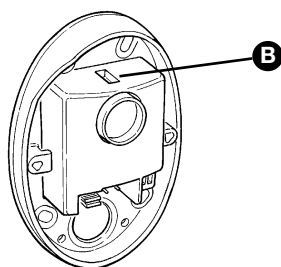

Figure 60

- 3 Make sure that the night light [C] on the KS1 key-operated selector switch is on.

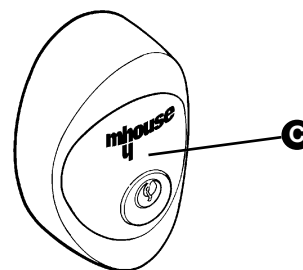

Figure 61

- 4 If the above conditions are not satisfied, you should immediately switch off the power supply to the control unit and check the cable connections more carefully. For more useful information see also chapters 5.5 "Troubleshooting" and 5.6 "Diagnostics and Signals".

3.5.1 Recognition of Connected Devices

When you have completed the initial checks, the control unit must recognize the devices connected to it on the "ECSBus" and "STOP" terminals.

- 1 On the control unit, press the P2 button [C] and hold it down for at least three seconds, then release the button.

- 2 Wait a few seconds for the control unit to finish recognizing the devices.

- 3 When the recognition procedure is completed, the STOP LED [A] must remain on, while the P2 LED [B] must go off. If the P2 LED flashes it means that an error has occurred: see paragraph 5.5 "Troubleshooting".

The connected devices recognition stage can be repeated again at any time, even after the installation (for example, if an additional photocell is installed); just repeat the procedure starting from step 1.

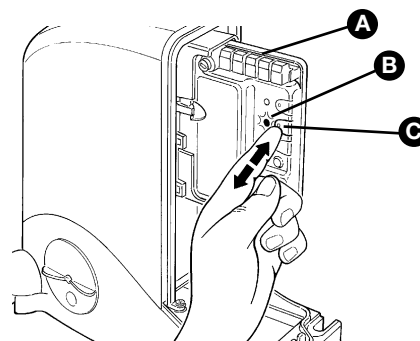

Figure 62

3.5.2 Checking gate movements

After recognizing the devices, the control unit must recognize the length of the gate. During this stage, the length of the gate is measured from the closing limit switch to the opening limit switch. This measurement is required to calculate the deceleration points and the partial opening point.

1 Release the gearmotor using the appropriate keys, see the "Gearmotor Release" paragraph on page 36, and move the gate to mid travel so that it is free to move in both opening and closing directions; then lock the gearmotor.

2 On the control unit press and release the OPEN button [A].

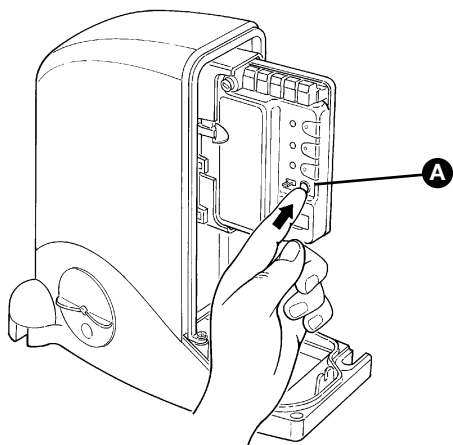

Figure 63

Wait for the control unit to open the gate until it reaches the opening limit switch.

• If the movement is not an opening manoeuvre, press the button again to stop the manoeuvre and invert the position of the jumper (see figure 50 or 51) on page 15. Then repeat point 2.

3 On the control unit press and release the OPEN button [A].

Wait for the control unit to close the gate until it reaches the closing limit switch.

4 Perform several opening and closing manoeuvres making sure that the gate reaches the limit switch and stops at least 2-3 centimetres before the mechanical stops.

3.5.3 Checking the Radio Transmitters

To check the transmitters just press one of the four buttons, make sure that the red LED flashes and that the automation executes the command.

The command associated to each button depends on how they have been memorized (see paragraph 5.4 "Memorization of Radio Transmitters"). The transmitters supplied have already been memorized and when you press the buttons the following commands are transmitted:

Button T1	"OPEN" command
Button T2	"Open pedestrian gate" command
Button T3	"Open only" command
Button T4	"Close only" command

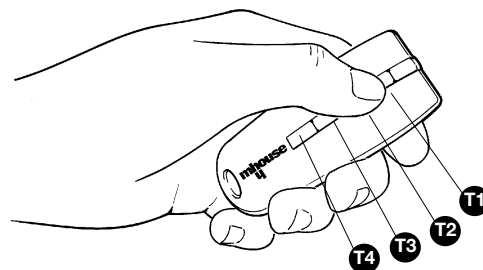

Figure 64

3.6 Regulations

3.6.1 Selecting gate speed

The gate can be opened and closed at two speeds: "slow" or "fast".

To switch from one speed to the other press the P2 button [B] momentarily; the corresponding P2 LED [A] will light up or go off; if the LED is off the speed is "slow", if the LED is on the speed is "fast".

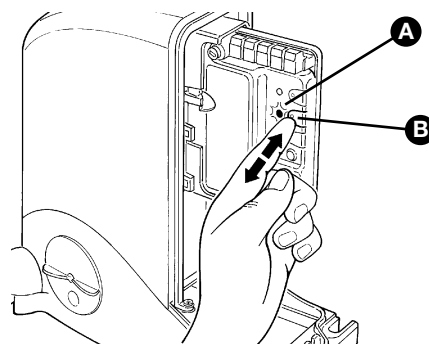

Figure 65

3.6.2 Selecting the Type of Operating Cycle

The opening and closing of the gate can take place according to different operating cycles:

- Single cycle (semiautomatic): the gate opens with a command and stays open until the next command is given, causing it to close.

- Complete cycle (automatic closing): the gate opens with a command and then closes automatically after a short time (for the time, see paragraph 5.1.1 "Adjusting the Parameters with the Radio Transmitter").

o switch from one operating cycle to the other, press the P3 button [B] momentarily; the corresponding LED [A] will light up or go off; if the LED is off the cycle is "single", if the LED is on the cycle is "complete".

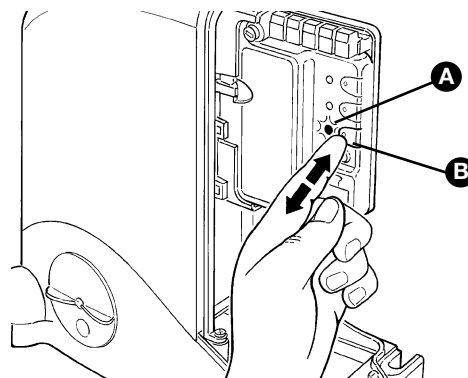

Figure 66

3.7 Testing and Commissioning

These are the most important operations, designed to guarantee the maximum safety and reliability of the automation system.

The testing procedure can also be used as a periodic check of the devices that make up the automation.

The testing and commissioning operations must be performed by qualified and experienced personnel who must establish what tests should be conducted based on the risks involved, and verify the compliance of the system with applicable regulations, legislation and standards, in particular with all the provisions of EN 12445 standard which establishes the test methods for gate automation systems.

3.7.1 Testing

1 Make sure that the provisions contained in chapter 1 "WARNINGS" have been carefully observed.

2 Using the selector switch or the radio transmitter, test the opening and closing of the gate and make sure that the leaves move in the intended direction.

The test should be carried out a number of times to make sure that the gate moves smoothly, that there are no points of excessive friction and that there are no defects in the assembly or adjustments.

3 Check the proper operation of all the safety devices, one by one (photocells, sensitive edges, etc.). In particular, each time a device is activated the "ECSBus" LED on the control unit flashes for a longer time, confirming that the control unit recognizes the event.

4 To check the photocells and make sure that there is no interference with other devices, pass a 5 cm diameter, 30 cm long cylinder on the optical axis, first near TX, then near RX and finally at the mid-point between them and make sure that in all these cases the device is triggered, switching from the active to the alarm status and vice-versa; finally, that it causes the intended action in the control unit, for example that it causes the reversal of the movement during the closing manoeuvre.

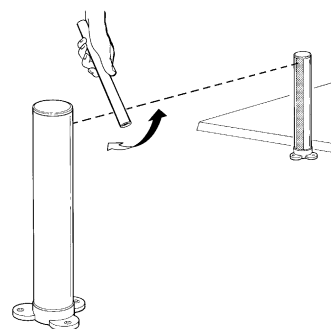

Figure 67

5 Measure the impact force according to EN 12445 standard. If "motor force" control is used to assist the system for the reduction of the impact force, try to find the adjustment that gives the best results.

3.7.2 Commissioning

The commissioning operations can be performed only after all the tests have been successfully carried out. Partial commissioning or implementation of "temporary" conditions are not permitted.

1 Prepare the technical documentation for the automation, which must include at least: assembly drawing (e.g. figure 1), wiring diagram (e.g. figure 17), analysis of hazards and solutions adopted, manufacturer's declaration of conformity of all the devices installed. Use enclosure "EC Declaration of conformity of the SL1 and SL10 components" for SL1 and SL10.

2 Post a label on the gate providing at least the following data: type of automation, name and address of manufacturer (person responsible for the "commissioning"), serial number, year of manufacture and "CE" marking.

3 Fill out the declaration of conformity and deliver it to the owner of the automation system; for this purpose you can use Annexe 2 "EC Declaration of Conformity".

4 Prepare the operating guide and deliver it to the owner of the automation system; Annexe 3 "OPERATING GUIDE" can be used as an example.

5 Prepare the maintenance schedule and deliver it to the owner of the automation system; it must provide directions regarding the maintenance of all the automation devices.

6 Before commissioning the automation system inform the owner regarding dangers and hazards that are still existing.

4 Maintenance

The maintenance operations must be performed in strict compliance with the safety directions provided in this manual and according to the applicable legislation and standards.

SL1 and SL10 automation devices do not require any particular maintenance operations; nevertheless, the perfect efficiency of all devices should be periodically checked at least every six months.

To this end, carry out all the tests and checks described in paragraph 3.7.1 "Testing" and the operations described in paragraph 7.3.3 "Maintenance Operations to Be Performed by the User".

If other devices are present, follow the directions provided in the corresponding maintenance schedule.

4.1 Dismantling and Disposal

SL1 and SL10 are constructed of various types of materials, some of which can be recycled (aluminium, plastic, electric cables), while others must be disposed of (electronic boards).

WARNING: some electronic components may contain polluting substances; do not pollute the environment. Enquire about the recycling or disposal systems available for SL1 and SL10 in compliance with regulations locally in force.

1 Contact a qualified electrician regarding the disconnection of the automation system from the electric mains.

2 Disassemble all the devices and accessories, following in reverse order the procedures described in chapter 3 "Installation".

3 Remove the batteries from the radio transmitters.

4 Remove the electronic boards.

5 Sort the various electrical and recyclable materials and consign them to licensed firms for recovery and disposal.

6 Consign the remaining materials to authorized scrap collection centres.

5 Additional information

The following chapters describe different ways of customizing SL1 and SL10 to make it suitable for specific application requirements.

5.1 Advanced Adjustments

5.1.1 Adjusting the Parameters with the Radio Transmitter

The radio transmitter can be used to adjust certain control unit operation parameters: there are four parameters and each of them can have four different values:

1) Pause time: time during which the leaves remain open (in the automatic closing mode).

2) Pedestrian gate: pedestrian gate opening mode.

3) Motor force: maximum force beyond which the control unit recognizes an obstacle and reverses the movement.

4) "OPEN" function: sequence of movements associated to each "OPEN" command.

Table 6

Parameter	N°	Setting	Action: operation to be performed at point 3 in the adjustment phase
Pause time	1st	10s	Press button T1 once
	2nd	20s (*)	Press button T1 twice
	3rd	40s	Press button T1 three times
	4th	80s	Press button T1 four times
Pedestrian gate	1st	Open gate to 0.7m	Press button T2 once
	2nd	Open gate to 1m (*)	Press button T2 twice
	3rd	Open gate halfway	Press button T2 three times
	4th	Open gate 3/4 of the way	Press button T2 four times
Motor force	1st	Low	Press button T3 once
	2nd	Medium-low (*)	Press button T3 twice
	3rd	Medium-high	Press button T3 three times
	4th	High	Press button T3 four times
"OPEN" function	1st	"Open"- "Stop"- "Close"- "Stop"	Press button T4 once
	2nd	"Open"- "Stop"- "Close"- "Open" (*)	Press button T4 twice
	3rd	"Open"- "Close"- "Open"- "Close"	Press button T4 three times
	4th	Opening only	Press button T4 four times

(*) Original factory setting

The parameter adjustment operation can be performed using any of the radio transmitters, provided they are memorized in mode 1 like the ones supplied (see paragraph 5.4.1 "Mode 1 memorization").

In the event that no transmitter memorized in Mode 1 is available, it is possible to memorize one just for this stage and delete it immediately afterwards (see paragraph 5.4.4 "Deleting a radio transmitter").

WARNING: when using the transmitter to make adjustments you need to give the control unit time to recognize the radio command; this means that the buttons must be pressed and released slowly, held down for at least one second, then released for one second and so on.

1 Press buttons T1 and T2 on the radio transmitter simultaneously for at least 5s

2 Release the two buttons.

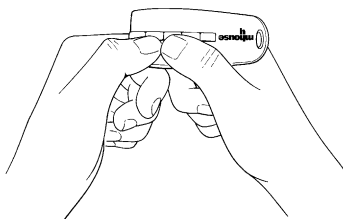

Figure 68

3 Within 3 seconds, perform the action described in Table 6 based on the parameter to be modified.

Esempio: to set the pause time at 40 s.

- 1° Press buttons T1 and T2 and hold them down for at least 5s
- 2° Release T1 and T2
- 3° Press button T1 three times

All the parameters can be adjusted as required without any contraindication; only the adjustment of the "motor force" requires special care:

- Do not use high force values to compensate for points of abnormal friction on the gate. Excessive force can compromise the operation of the safety system or damage the gate.
- If the "motor force" control is used to assist the impact force reduction system, measure the force again after each adjustment in compliance with EN 12445 standard.
- The weather conditions may affect the movement of the gate, therefore periodic re-adjustments may be necessary.

5.1.2 Checking the Adjustments with the Radio Transmitter

With a radio transmitter memorized in mode 1, the adjustment values for each parameter can be checked at any time using the following sequence:

- 1 Press buttons T1 and T2 on the radio transmitter simultaneously for at least 5s.
- 2 Release the two buttons.
- 3 Within 3 seconds, perform the action described in Table 7 based on the parameter to be checked.
- 4 Release the button when the flashing light starts flashing
- 5 Count the flashes and, based on their number, check the corresponding value in table 6.

Table 7

Parameter	Action
Pause time	Press button T1 and hold it down
Pedestrian gate	Press button T2 and hold it down
Motor force	Press button T3 and hold it down
"OPEN" function	Press button T4 and hold it down

Example: If the flashing light flashes three times after you have pressed T1 and T2 for 5s and then button T1, the pause time is set at 40s.

5.2 Optional Accessories

In addition to the devices featured in SL1 and SL10, other ones are available as optional accessories designed to enhance the automation system.

PR1: 24V buffer battery for supply in the event of power failure. It guarantees at least 10 complete cycles. When the system is powered by the battery, the manoeuvre takes place only in "slow" speed mode.

PT50: Pair of 500 mm posts with one photocell.

PT100: Pair of 1000 mm posts with two photocells.

For information on the new accessories, refer to the MHOUSE catalogue or visit the site www.mhouse.biz.

5.3 Adding or Removing Devices

Devices can be added or removed from an SL1 and SL10 automation system at any time.

Do not add any devices until you have made sure that they are perfectly compatible with SL1 and SL10; for further information contact MHOUSE Customer Service.

5.3.1 ECSBus

ECSBus is a system that allows you to connect the ECSBus devices using only two wires which carry both the power supply and the communication signals. All the devices are connected in parallel on the 2 wires of the ECSBus itself; each device is individually recognized because a univocal address is assigned to it during the installation.

The photocells, as well as other devices that adopt this system, can be connected to ECSBus, such as safety devices, control buttons, signalling lights etc. For information on the ECSBus devices, refer to the MHOUSE catalogue or visit the site www.mhouse.biz.

The control unit recognizes all the connected devices individually through a suitable recognition process, and can detect all the possible abnormalities with absolute precision. For this reason, each time a device connected to ECSBus is added or removed the control unit must go through the recognition process; see paragraph 5.3.3 "Recognition of Other Devices".

5.3.2 STOP Input

STOP is the input that causes the immediate interruption of the manoeuvre (with a short reverse run). Devices with output featuring normally open "NO" contacts (like the KS1 selector switch) and devices with normally closed "NC" contacts, as well as devices with 8.2K Ω constant resistance output, like sensitive edges, can be connected to this input. Multiple devices, even of different type, can be connected to the STOP input if suitable arrangements are made.

To do this, proceed as described in the following table:

Table 8

		1st device type:		
		NO	NC	8,2k Ω
2nd device type	NO	In parallel (note 2)	(note 1)	In parallel
	NC	(note 1)	In series (note 3)	In series
	8,2k Ω	in parallel	In series	in parallel (note 4)

Note 1. The NO and NC combination can be obtained by placing the two contacts in parallel, and placing in series to the NC contact an 8.2K Ω resistance (therefore, the combination of 3 devices is also possible: NO, NC and 8.2K Ω).

Note 2. Any number of NO devices can be connected to each other in parallel.

Nota 3. Any number of NC devices can be connected to each other in series.

Nota 4. Only two devices with 8.2K Ω constant resistance output can be connected in parallel; if needed, multiple devices must be connected "in cascade" with a single 8.2K Ω termination resistance.

Warning: if the STOP input is used to connect devices with safety functions, only the devices with 8.2K Ω constant resistance output guarantee the fail-safe category 3.

During the recognition stage the control unit, like ECSBus, recognizes the type of device connected to the STOP input; subsequently it commands a STOP whenever a change occurs in the recognized status.

5.3.3 Recognition of Other Devices

Normally the recognition of the devices connected to the ECSBus and the STOP input takes place during the installation stage. However, if new devices are added or old ones removed, the recognition process can be gone through again by proceeding as follows:

- 1 On the control unit, press the P2 [B] button and hold it down for at least five seconds, then release it.
- 2 Wait a few seconds for the control unit to finish recognizing the devices.
- 3 When the recognition stage is completed the P2 LED [A] should go off. If the P2 LED flashes it means that an error has occurred: see paragraph 5.5 "Troubleshooting".
- 4 After you have added or removed any devices, the automation system must be tested again according to the directions contained in paragraph 3.7.1 "Testing".

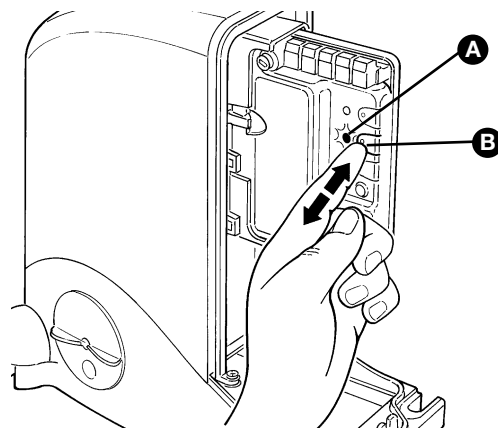

Figure 69

5.3.4 Addition of Optional Photocells

Additional photocells can be installed at any time in addition to those supplied with SL1 and SL10. In an automation system for sliding gates these can be arranged as shown in figure 70.

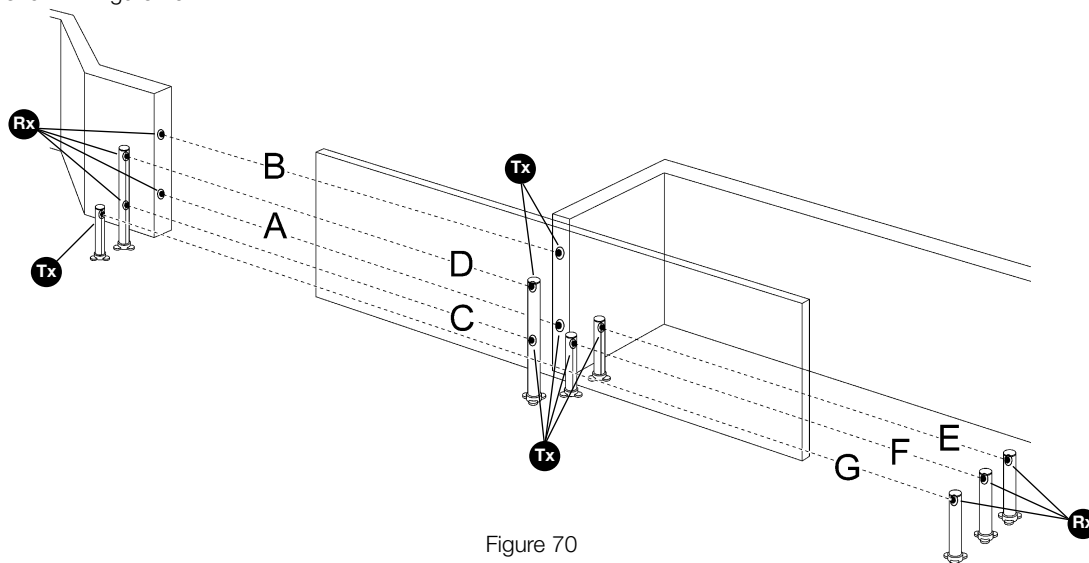

Figure 70

Table 9

Photocell	Jumpers	Photocell	Jumpers
A External photocell h=50cm; activated when gate closes		E External photocell activated when gate opens	
B External photocell h=100cm; activated when gate closes		F Internal photocell activated when gate opens	
C Internal photocell h=50cm; activated when gate closes		G Single photocell for the entire automation system activated when the gate both opens and closes	
D Internal photocell h=100cm; activated when gate closes			

Note: the two photocell elements (TX-RX) can be positioned wherever you like. Only if photocell G is used together with photocell B must the position of the elements shown in figure 70 be respected.

To ensure the correct recognition of the photocells by the control unit, the former must be assigned addresses by means of jumpers. The address allocation procedure must be performed on TX as well as RX (arranging the jumpers in the same manner), but you must make sure that there are no other pairs of photocells having the same address.

The photocells need to be assigned addresses to make sure that they are correctly recognized among the other ECSBus devices, and in order to assign the performed function.

- 1 Open the shell of the photocell.
- 2 Identify the position where they are installed based on figure 70 and connect with jumper according to Table 9.

The unused jumpers must be stored in their proper compartment for future use.

- 3 Perform the recognition stage as explained in paragraph 5.3.3 "Recognition of other devices".

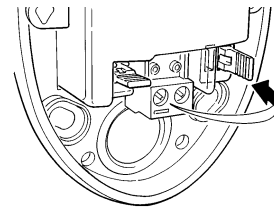

Figure 71

5.4 Memorization of Radio Transmitters

The control unit contains a radio receiver for TX4 transmitters; those included in the package are pre-memorized and operative.

If you wish to memorize a new radio transmitter you have two choices:

- Mode 1: in this "mode" the radio transmitter is used to its full extent, i.e. all the buttons execute a pre-established command (the transmitters supplied with SL1 and SL10 are memorized in Mode 1). It is obvious that in Mode 1 a radio transmitter can be used to command a single automation, i.e.:

T1 button	"OPEN" command
T2 button	"Pedestrian gate" command
T3 button	"Open only" command
T4 button	"Close only" command

- Mode 2: one of the four commands available can be associated to each button. This mode, used properly, allows you to command 2 or more different automations; for example:

T1 button	"Open only" command	Automation N. 1
T2 button	"Close only" command	Automation N. 1
T3 button	"OPEN" command	Automation N. 2
T4 button	"OPEN" command	Automation N. 3

Each transmitter is, of course, a separate unit, and while some are memorized in mode 1 others can be memorized in mode 2 on the control unit.

The overall memory capacity is 150 units; memorization in mode 1 takes up one unit for each transmitter while mode 2 takes up one unit for each button.

Warning: since the memorization procedures are timed (10s), you must read the instructions in the following paragraphs before you proceed with their execution.

5.4.1 Memorization Mode 1

- 1 Press button P1 [B] for at least 3s. When the P1 LED [A] lights up, release the button.

- 2 Within 10s, press any button on the radio transmitter to be memorized and hold it down for at least 3s.

If the memorization procedure is successful, the "P1" LED will flash 3 times.

- 3 If there are other transmitters to be memorized, repeat step 2 within the next 10s, otherwise the memorization stage will terminate automatically.

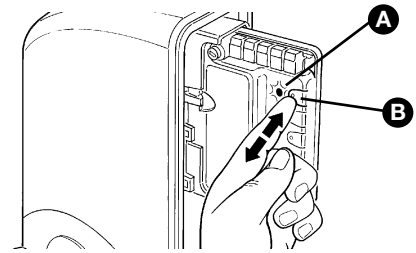

Figure 72

5.4.2 Memorization Mode 2

With the memorization in mode 2 of the radio transmitter, any one of the four commands ("OPEN", "Open partially", "Open only" and "Close only") can be associated to each button.

In Mode 2 each button requires a separate memorization stage.

- 1 If the transmitter to be memorised is already memorised (this is when the transmitters that are supplied have already been memorised in Mode 1), it must firstly be deleted by following the procedure in "5.4.4 Deleting a radio transmitter".

- 2 Press button P1 (figure 72) on the control unit as many times as the number corresponding to the desired command, according to the following table, (e.g. 3 times for the "Open only" command):

1 time	"OPEN" command
2 times	"Pedestrian gate" command
3 times	"Open only" command
4 times	"Close only" command

- 3 Make sure that the P1 LED makes as many quick flashes as the number corresponding to the selected command.

- 4 Within 10 s, press the desired button on the radio transmitter to be memorized, and hold it down for at least 2 s.

If the memorization procedure is successful, the "P1" LED will flash 3 times slowly.

- 5 If there are other transmitters to be memorized for the same type of command, repeat step 3 within the next 10s, otherwise the memorization stage will terminate automatically.

5.4.3 "Remote" Memorization

A new radio transmitter can be memorized in the control unit without directly operating the buttons on it. You need to have an "OLD" pre-memorized operational radio transmitter. The "NEW" radio transmitter to be memorized will inherit the characteristics of the OLD one, i.e. if the OLD radio transmitter was memorized in Mode 1, the NEW one will also be memorized in Mode 1. In this case, during the memorization stage you can press any key on the two transmitters. If, on the other hand, the OLD transmitter was memorized in Mode 2 you must press the button on the OLD transmitter which corresponds to the desired command, and the button on the NEW transmitter to which you wish to associate that command.

Holding the two transmitters, position yourself within the operating range of the automation and perform the following operations:

- 1 Press the button on the NEW radio transmitter and hold it down for at least 5s, then release it.
- 2 Press the button on the OLD radio transmitter 3 times slowly.
- 3 Press the button on the NEW radio transmitter once slowly.

At this point the NEW radio transmitter will be recognized by the control unit and will assume the characteristics of the OLD one.

If there are other transmitters to be memorized, repeat all the steps above for each new transmitter.

5.4.4 Deleting a Radio Transmitter

If a radio transmitter is available, this operation allows you to delete it.

If the transmitter is memorized in Mode 1, a single deletion stage is sufficient: just press any button at point 3. If the transmitter is memorized in Mode 2, one deletion stage is needed for each memorized button.

- 1 Press and hold down button P1 [B] (Figure 72) on the control unit.
- 2 Wait until the P1 LED [A] lights up, then, within three seconds:

3 Press and hold down for at least three seconds the button of the radio transmitter to be deleted. If the radio transmitter has been deleted, the P1 LED will flash quickly five times. If the LED flashes slowly just once, it means that the deletion has not taken place because the transmitter is not memorized

4 If there are more transmitters to be deleted, repeat step 3 within ten seconds while pressing button P1, otherwise the deletion stage will terminate automatically.

5.4.5 Deleting all the Radio Transmitters

With this operation all the memorized transmitters are deleted.

- 1 Press the P1 button [B] on the control unit and hold it down.
- 2 Wait until the P1 LED [A] lights up, then wait until it goes off, then wait until it has flashed 3 times.
- 3 Release the P1 button precisely upon the third flash.
- 4 Wait approximately 4s for the deletion process to be completed; during this time the LED will flash very quickly.

If the procedure is successful, after a few moments the "P1" LED will flash slowly 5 times.

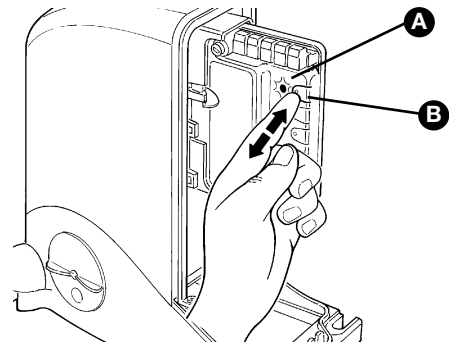

Figure 73

5.5 Troubleshooting

The following table contains instructions to help you solve malfunctions or errors that may occur during the installation stage or in case of failure.

Table 10

Symptoms	Probable cause and possible solution
The radio transmitter does not emit any signal (the LED [A] does not light up)	<ul style="list-style-type: none"> • Check to see if the batteries are exhausted, if necessary replace them (page 36)
The manoeuvre does not start and the "ECSBus" LED [B] does not flash	<ul style="list-style-type: none"> • Make sure that the power cord is properly plugged into the mains outlet • Check to see if the fuses [E] or [F] are blown; if necessary, identify the reason for the failure and then replace the fuses with others having the same current rating and characteristics.
The manoeuvre does not start and the flashing light is off	<ul style="list-style-type: none"> • Make sure that the command is actually received. If the command reaches the OPEN input, the corresponding "OPEN" LED [D] must light up; if you are using the radio transmitter, the "ECSBus" LED must make two long flashes.
The manoeuvre does not start and the flashing light flashes a few times	<ul style="list-style-type: none"> • Make sure that the STOP input is active, i.e. that the "STOP" LED [C] comes on. If this does not happen, check the devices connected to the STOP input. • The photocell test which is performed at the starting of each manoeuvre is not successful; check the photocells, also according to Table 11 on page 27.
The manoeuvre starts but it is immediately followed by a reverse run	<ul style="list-style-type: none"> • The selected force is too low to move the gate. Check to see whether there are any obstacles; if necessary increase the force as described on page 21.
The manoeuvre is carried out but the flashing light does not work	<ul style="list-style-type: none"> • Make sure that there is voltage on the flashing light's FLASH terminal during the manoeuvre (being intermittent, the voltage value is not important: approximately 10-30Vac); if there is voltage, the problem is due to the lamp; in this case replace the lamp with one having the same characteristics.

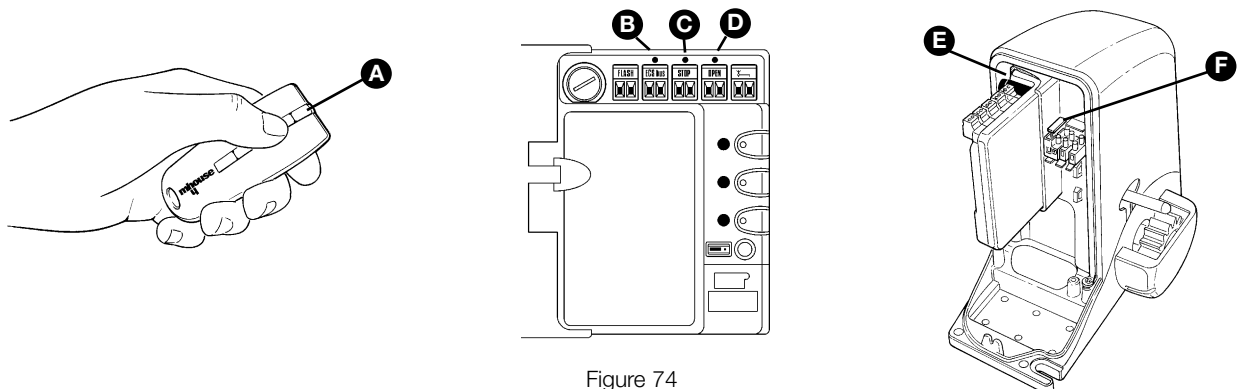

Figure 74

5.6 Diagnostics and Signals

A few devices issue special signals that allow you to recognize the operating status or possible malfunctions.

5.6.1 Photocells

The photocells are equipped with a "SAFE" LED [A] that allows you to check the operating status at any time.

Table 11

"SAFE" LED	Status	Action
Off	The photocell is not powered or is faulty	Make sure that there is voltage (approx. 8-12 Vdc) on the photocell's terminals; if the voltage is correct, the photocell is probably faulty.
3 quick flashes and a second's pause	Device not recognized by the control unit	Repeat the recognition procedure on the control unit. Make sure that all the photocell pairs on ECSBus have different addresses (see Table 9 on page 23)
1 very slow flash	The RX receives a perfect signal	Normal operation
1 slow flash	The RX receives a fair signal	Normal operation
1 quick flash	The RX receives a poor signal	Normal operation but you should check the TX-RX alignment and make sure the glasses are clean
1 very quick flash	The RX receives a very poor signal	It is at the limit of normal operation, you should check the TX-RX alignment and make sure the glasses are clean
Always on	The RX does not receive any signal	Check to see if there is an obstacle between TX and RX. Make sure that the LED on TX flashes once slowly. Check the TX-RX alignment

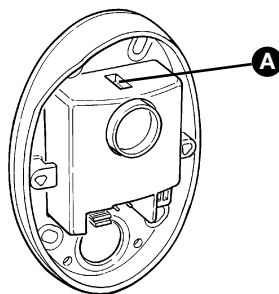

Figure 75

5.6.2 Flashing light

During the manoeuvre the flashing light flashes once every second. When something is wrong the flashes are more frequent (half a second); the light flashes twice with a second's pause between flashes.

Table 12

Quick flashes	Status	Action
1 flash 1 second's pause 1 flash	ECSBus error	At the starting of the manoeuvre, the devices present do not correspond to those recognized; check and if necessary try repeating the recognition process. (see 5.3.3 "Recognition of Other Devices"). One or more devices may be faulty; check and, if necessary, replace them.
2 flash 1 second's pause 2 flashes	Triggering of a photocell	At the starting of the manoeuvre, one or more photocells do not enable it; check to see if there are any obstacles. If there is an obstacle impeding the movement no action is required.
3 flash 1 second's pause 3 flashes	Cutting in of the "motor force" limiting device	During the movement, the leaf experienced excessive friction; identify the cause
4 flash 1 second's pause 4 flashes	Cutting in of the STOP input	During the movement the STOP input was activated; identify the cause

5.6.3 Control Unit

On the control unit there is a set of LED's each of which can give special indications both during normal operation and in case of malfunctions.

Table 15

ECSBus LED [A]	Status	Action
Off	Malfunction	Make sure there is power supply; check to see if there are blown fuses; identify the cause of the malfunction and then replace blown fuses with others having the same characteristics
On	Serious malfunction	There is a serious malfunction; try switching off the control unit for a few seconds; if the condition persists it means there is a malfunction and the electronic board has to be replaced
One flash every second	Everything OK	Normal operation of control unit
2 long flashes	The status of the inputs has changed	This is normal when there is a change in one of the inputs: OPEN, STOP, triggering of photocells or the radio transmitter is used
Series of flashes separated by a pause	It corresponds to the flashing light's signal. See Table 14	
Quick flash	Short circuit on ECSBus	An overload has been detected and therefore the power supply to the ECSbus has been interrupted. Check by disconnecting the devices one by one, if necessary. To restore the power supply to the ECSBus just give the command using the radio transmitter, for example.
STOP LED [B]	Status	Action
Off	Cutting in of the STOP input	Check the devices connected to the STOP input
On	Everything OK	STOP input active
OPEN LED [C]	Status	Action
Off	Everything OK	OPEN input not active
On	Cutting in of the OPEN input	This is normal only if the device connected to the OPEN input is actually active
P1 LED [D]	Status	Action
Off	Everything OK	No memorization in progress
On	Memorization in Mode 1	This is normal during memorization in Mode 1 which lasts maximum 10s
Series of quick flashes, from 1 to 4	Memorization in Mode 2	This is normal during memorization in Mode 2 which lasts maximum 10s
5 quick flashes	Deletion OK	Deletion of one transmitter successful.
1 slow flash	Wrong command	A command from a non-memorized transmitter has been received
3 slow flashes	Memorization OK	Memorization process successful.
5 slow flashes	Deletion OK	Deletion of all transmitters successful.
P2 LED [E]	Status	Action
Off	Everything OK	"Slow" speed selected
On	Everything OK	"Fast" speed selected
1 flash every second	No device has been memorized or an error has occurred during the recognition process	There may be faulty devices; check and, if necessary, try repeating the recognition process (see paragraph 3.5.1 "Learning of Connected Devices")
2 flashes per second	Device recognition stage in progress	It indicates that the search for the connected devices is under way (this stage lasts a few seconds at the most)
P3 LED [F]	Status	Action
Off	Everything OK	Single cyclic operation
On	Everything OK	Complete cyclic operation

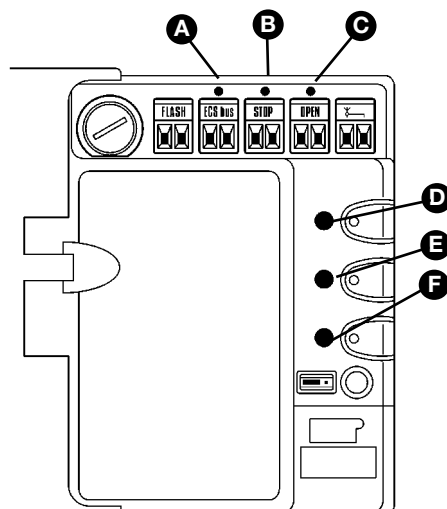

Figure 76

6 Technical Characteristics

SL1 and SL10 are produced by NICE S.p.a. (TV) I, MHOUSE S.r.l. is an affiliate of the Nice S.p.a group.

Nice S.p.a., in order to improve its products, reserves the right to modify their technical characteristics at any time without prior notice. In any case, the manufacturer guarantees their functionality and fitness for the intended purposes.

Note: all the technical characteristics refer to a temperature of 20°C.

Model type	SL1	SL10
Type	Electromechanical gearmotor for automated gates and doors incorporating a control unit complete with radio receiver for "TX4" transmitters.	
Adopted technology	24Vdc motor, helical teeth reduction gear; mechanical release A transformer inside the motor but separated from the control unit reduces mains voltage to the nominal voltage of 24Vdc used by the automation system	
Peak thrust	18Nm	34Nm
Nominal torque	5,2Nm	7,5Nm
Nominal thrust	173N	250N
Idling speed	0,16 m/s in "slow" speed mode; 0,25 m/s in "fast" speed mode	0,12 m/s in "slow" speed mode; 0,18 m/s in "fast" speed mode
Nominal torque speed	0,06 m/s in "slow" speed mode; 0,11 m/s in "fast" speed mode	0,06 m/s in "slow" speed mode; 0,11 m/s in "fast" speed mode
Maximum frequency of cycles	50 complete cycles per day For a maximum of 12 cycles per hour. A maximum of 4 cycles per hour is permitted at 50°C	
Maximum continuous cycle time	6 minutes	6 minutes
Working Limits	Its structural characteristics make it suitable for use on gates weighing up to 350Kg and up to 5m long	Its structural characteristics make it suitable for use on gates weighing up to 500Kg and up to 7m long
SL1- SL10 power supply	230Vac (+10% -15%) 50/60Hz	
SL1- SL10 / V power supply	120Vac (+10% -15%) 50/60Hz	
Maximum absorbed power	300W	420W
Emergency power supply	Designed to accommodate "PR1" buffer batteries	
Flashing light output	For visual signalling devices with 12V lamp, maximum 21W	
ECSBus output	One output with a maximum load of 10 ECSBus units	
"OPEN" input	For normally open contacts (the closing of the contact causes the "OPEN" command)	
STOP input	For normally open contacts and/or for 8.2K Ω constant resistance, or normally closed contacts with recognition of the "normal" status (any variation from the memorized status causes the "STOP" command)	
Radio aerial input	52 Ω for RG58 or similar type of cable	
Maximum cable length	Mains power supply: 30m; inputs/outputs: 20m with aerial cable preferably shorter than 5m (observe the directions regarding the minimum gauge and type of cable)	
Operating ambient temperature	-20 ÷ 50°C	
Not suitable for use in acid, saline or potentially explosive atmosphere	No	
Mounting	Horizontal surface-mounted with relative fixing plate	
Protection class	IP44	
Dimensions / weight	300 x 163 h 295 mm / 9 Kg	300 x 163 h 295 mm / 10 Kg
Remote control possibility	With TX4 transmitters the control unit can receive one or more of the following commands: "OPEN", "Open partially", "Open only" and "Close only"	
TX4 transmitters memorized	Up to 150 if memorized in mode 1	
Range of TX4 transmitters	From 50 to 100m. The range can vary if there are obstacles or electromagnetic disturbances, and is affected by the position of the receiving aerial incorporated in the flashing light	
Programmable functions	"Cycle" or "Complete cycle" operation (automatic closing) "Slow" or "fast" motor speed The pause time in the "complete cycle" mode can be set at 10, 20, 40, 80 seconds The type of pedestrian opening can be selected from 4 modes The sensitivity of the obstacle detection system can be selected from 4 levels The operation of the "Open" command can be selected from 4 modes	
Self-programmed functions	Automatic detection of devices connected to the ECSBus output Automatic detection of the type of "STOP" device (NO or NC contact or 8.2K Ω resistance) Automatic detection of gate length and calculation of deceleration points	

PH1 Photocells

Tipologia	Presence detector for automated gates and doors (type D according to EN 12453 standard) consisting of a "TX" transmitter and an "RX" receiver
Adopted technology	Optical, by means of direct TX-RX interpolation with modulated infrared ray
Detection capacity	Opaque objects located on the optical axis between TX and RX, larger than 50mm and moving slower than 1.6m/s
TX transmission angle	Approx. 20°
RX reception angle	Approx. 20°
Useful capacity	Up to 10m for maximum TX-RX misalignment of ± 5° (the device can signal an obstacle even in the case of adverse weather conditions)
Power supply/output	The device can be connected only to "ECSBus" networks from which it receives the power supply and sends the output signals.
Absorbed power	1 ECSBus unit
Maximum cable length	Up to 20m (observe the directions regarding the minimum gauge and type of cable)
Addressing possibility	Up to 7 detectors with protection function and 2 with opening command function. The automatic synchronism prevents any interference among the various detectors
Operating ambient temperature	-20 ÷ 50°C
Suitable for use in acid, saline or potentially explosive atmosphere	No
Mounting	Vertical, wall-mounted
Protection class	IP44
Dimensions / weight (TX and RX)	95 x 65 h 25mm / 65g

KS1 Key-Operated Selector Switch

Type	Key-operated double switch suitable for control of automatic gates and doors. Illuminated for night operation
Adopted technology	Activation protected by a lock, the insertion and clockwise turning of the key causes the closing of a contact, the counter-clockwise turning of the key causes the closing of the second contact; spring-loaded for return of key to the middle position
Tamper-proof	The selector switch can be opened to access the connections only by inserting the key and turning it in either direction
Security lock	Key with 450 different key numbers
Power supply/contacts	The device can only be connected to the "OPEN" and "STOP" terminals on the MHOUSE automation control units, to which it sends the control signals and by which it is energized for night illumination
Operating ambient temperature	-20 ÷ 50°C
Suitable for use in acid, saline or potentially explosive atmosphere	No
Mounting	Vertical, wall mounted
Protection class	IP44
Dimensions / weight	95 x 65 h 36mm / 135g

FL1 Flashing light

Type	Flashing signalling light for automatic gates and doors. The device incorporates a receiving aerial for remote control
Adopted technology	Visual signalling device with 12V 21W lamp, controlled by MHOUSE automation control units
Lamp	12V 21W BA15 socket (automotive type lamp)
Power supply	The device can be connected only to the "FLASH" and "AERIAL" terminals on the MHOUSE automatic gate control units
Operating ambient temperature	-20 ÷ 50°C
Suitable for use in acid, saline or potentially explosive atmosphere	No
Mounting	Horizontal surface-mounted or vertical wall-mounted
Protection class	IP44
Dimensions / weight	120 x 60 h 170mm / 285g

TX4 transmitters

Type	Radio transmitters for remote control of automatic gates and doors
Adopted technology	AM OOK coded modulation of radio carrier
Frequency	433.92 Mhz
Coding	Rolling code with 64 Bit code (18 billion million combinations)
Buttons	4, each button can be used for the different controls of the same control unit or to control different control units.
Irradiated power	Approx. 0.0001W
Power supply	6V +20% -40% with two CR2016 type lithium batteries
Battery life	3 years, estimated on the basis of 10 commands/day, each lasting 1s at 20°C (at low temperatures the efficiency of the batteries decreases)
Operating ambient temperature	-20 ÷ 50°C
Suitable for use in acid, saline or potentially explosive atmosphere	No
Protection class	IP40 (suitable for use indoors or in protected environments)
Dimensions / weight	72 x 31 h 11mm / 18g

7 Annexes

The following annexes are designed to help you prepare the technical documentation

7.1 Enclosure 1: CE Declaration of Conformity of the SL1 and SL10 components

CE Declaration of Conformity of the SL1 and SL10 components; the declaration is enclosed to the technical documentation.

7.2 Annexe 2: CE Declaration of Conformity of Power Operated Gate

CE Declaration of Conformity to be filled in and delivered to the owner of the power operated gate.

7.3 Annexe 3: Operating Guide

Brief guide to be used as an example for drafting the operating guide to be delivered to the owner of the power operated gate.

Declaration of conformity

CE Declaration of Conformity according to the directives 98/37/EC, 73/23/EEC, 89/336/EEC and 1999/5/EC
SL1 and SL10 are produced by NICE S.p.a. (TV) I, MHOUSE S.r.l. is an affiliate of the NICE S.p.a. group

Number: 159/SL1/GB

Data: 02/02/2005

Revision: 1

The undersigned Lauro Buoro, managing director, declares under his sole responsibility that the following product:

Manufacturer's name: NICE s.p.a.

Address: Via Pezza Alta 13, 31046 Z.I. Rustignè, Oderzo (TV) Italia

Type: Electromechanical gearmotor with incorporated control unit and radio receiver

Model: SL1, SL10

Accessories: TX4, PH1, KS1, FL1

Satisfies the essential requirements of the following Directives:

Reference	Heading
98/37/EC (modified 89/392/EEC)	DIRECTIVE 98/37/EC OF THE EUROPEAN PARLIAMENT AND OF THE COUNCIL of June 22, 1998, for the harmonisation of the legislations of member States regarding machines.
According to Annexe II, part B (EC declaration of conformity by the manufacturer)	

As specified in the 98/37/EC directive, the use of the above mentioned product is not admitted until the machine, on which this product is mounted, has been identified and declared as conforming to the directive 98/37/EC.

Satisfies the essential requirements of the following Directives, as amended by the directive 93/68/EEC of the council of 22nd July 1993.

Reference	Heading
73/23/EEC	DIRECTIVE 73/23/EEC OF THE COUNCIL of February 19, 1973 for the harmonisation of the legislations of member States regarding electrical equipment designed to be used within certain voltage limits.
According to the following harmonised standards: EN 60335-1.	
89/336/EEC	DIRECTIVE 89/336/EEC OF THE COUNCIL of May 3, 1989, for the harmonisation of the legislations of member States regarding electromagnetic compatibility.
According to the following harmonised standards: EN 61000-6-2; EN 61000-6-3.	

Furthermore, the product complies with the essential requisites specified in article 3 of the following EC directive, for the use the products have been manufactured for:

Reference	Heading
1999/5/EC	DIRECTIVE 1999/5/EC OF THE EUROPEAN PARLIAMENT AND OF THE COUNCIL of March 9, 1999 concerning radio equipment and telecommunications terminal equipment and mutual recognition of their conformity.
According to the following standards: ETSI EN 300 220-3; ETSI EN 301 489-1; ETSI EN 301 498-3.	

Oderzo, 2nd February 2005

Lauro Buoro
(Managing Director)



Declaration of conformity

According to Directive 98/37/EC, ANNEXE II, part A (CE declaration of conformity for machines)

The undersigned / Company:

(name or business name of person who has put the power operated gate into service)

(address)

Declares under his/her sole responsibility that:

The automation : power operated gate

Serial number : _____

Year of manufacture : _____

Location (address) : _____

Satisfies the essential requirements of the following Directives:

98/37/EC Machine Directive

89/336/EEC Electromagnetic Compatibility Directive

73/23/EEC Low Voltage Directive

99/5/EC "R&TTE" Directive

And the provisions of the following harmonised standards:

EN 12445 "Industrial, commercial and garage doors and gates. Safety in use of power operated doors - Test methods"

EN 12453 "Industrial, commercial and garage doors and gates. Safety in use of power operated doors - Requirements"

Name _____ Signature _____

Date _____ Location _____



7.3 Annexe 3: Operating Guide

This guide should be stored in an accessible location and made available to all users of the automation.

7.3.1 Safety regulations

- **Keep at a safe distance while the gate is moving; do not pass through until the gate has opened all the way and has stopped moving.**
- **Do not allow children to play near the gate or with its controls.**
- **Stop using the automation system immediately if you notice anything abnormal (strange noise or jerky movements); failure to observe this warning may result in serious danger and accidents.**

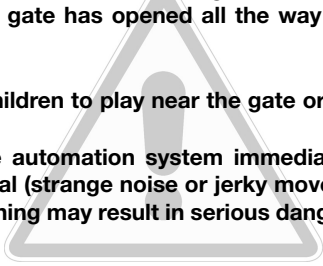

- **Do not touch any components while they are moving.**
- **Have periodic checks made according to the instructions provided in the maintenance schedule.**
- **Maintenance operations and repairs can only be performed by qualified technicians.**

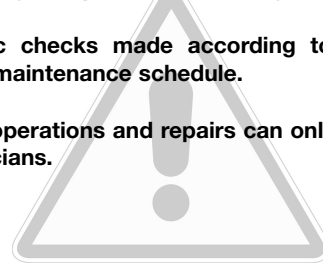

7.3.2 Gate Control

With radio transmitter

The radio transmitter is ready for use and the four buttons have the following functions:

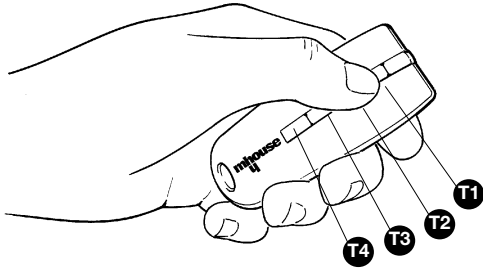

Figure 77

Function(*)	
T1 button	
T2 button	
T3 button	
T4 button	

(*) This table must be prepared by the person who has programmed the system:

With selector switch

The selector switch has two positions, with automatic return to the centre.

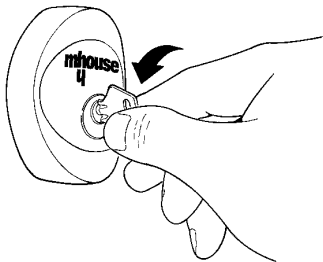

Figure 78

Action	Function
Rotated to the right: "OPEN"	(*)
Rotated to the left: "STOP"	It stops the movement of the gate

(*) This item must be drafted by the person who has programmed the system.

Control with safety devices out of order

If the safety devices are out of order or malfunctioning, it is still possible to control the gate.

1 Operate the gate control device (remote control or key-operated selector switch). If the safety devices enable the operation, the gate will open normally, otherwise:

2 The flashing light flashes a few times but the manoeuvre does not start (the number of flashes depends on the reason why the manoeuvre is not enabled).

3 In this case, actuate the control again within 3 seconds and keep it actuated.

4 After approximately 2s the gate will start moving in the "man present" mode, i.e. so long as the control is maintained the gate will keep moving; as soon as the control is released the gate will stop.

If the safety devices are out of order the automation must be repaired as soon as possible.

Gearmotor release

SL1 and SL10 are equipped with a mechanical system that allows the gate to be opened and closed manually (or rather, as if there was no gearmotor).

The manual operation must be resorted to in case of power failures or system malfunctions. If a power failure occurs, the buffer battery can be used (PR1 optional accessory).

If there is a malfunction of the gearmotor it is still possible to try and release the motor in order to check whether the problem is connected with the release mechanism.

1 Turn the release mechanism cover anti-clockwise until the hole matches the release pin.

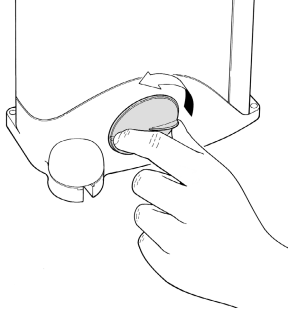

Figure 79

2 Insert the key in the pin.

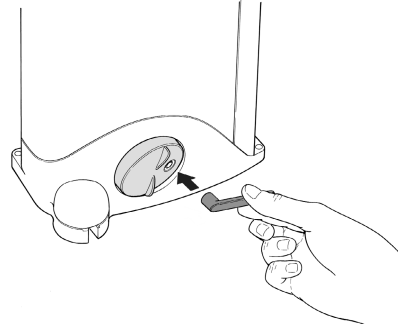

Figure 80

3 Turn the key anti-clockwise by approx. 90° until you feel the gate release

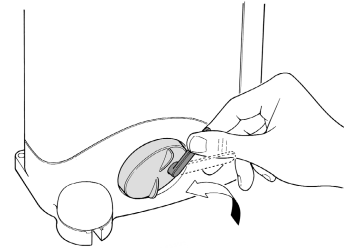

Figure 81

4 At this point, the gate can be moved manually.

5 To restore the functionality of the automation system, rotate the key clockwise while simultaneously moving the gate until it is caught by the mechanism.

6 Remove the key and close the cover by turning it clockwise.

7.3.3 Maintenance Operations to Be Performed by the User

The only maintenance operations that the user can and must perform periodically concern the cleaning of the photocell glasses and the removal of leaves and debris that may impede the automation.

• **Use a slightly damp cloth (not wet) to clean the surface of the devices. Do not use any substances containing alcohol, benzene, diluents or other flammable substances. The use of these substances could damage the devices, start fires or generate electric shocks.**

• **Disconnect the power supply to the automation before you proceed to remove leaves and debris, to prevent anyone from activating the gate.**

7.3.4 Replacing the Remote Control Battery

If the range of the remote control is significantly diminished and the light emitted by the LED is feeble, the remote control battery is probably exhausted. The remote control houses two CR2016 type lithium batteries. To replace them proceed as follows:

1 Open the bottom by pulling it.

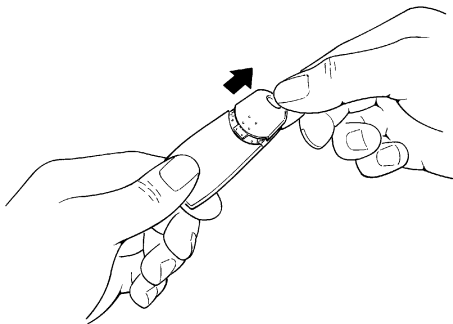

Figure 82

2 Insert a small pointed tool in the slit and prise the batteries out.

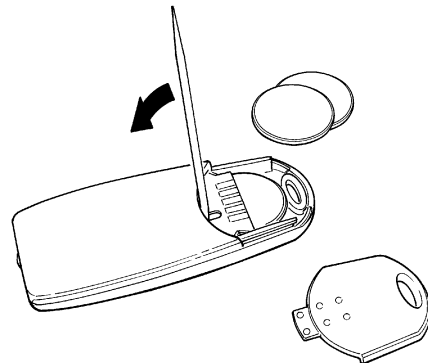

Figure 83

3 Insert the new battery, observing the polarity (the "+" symbol towards the bottom).

4 Close the bottom until it clicks.

The batteries contain polluting substances: do not dispose of them together with other waste but use the methods established by local regulations.

Mhouse

Via Pezza Alta, 13 - Z.I. Rustignè
31046 Oderzo TV Italia
Tel. +39 0422 20 21 09
Fax +39 0422 85 25 82
info@mhouse.biz
www.mhouse.biz

